

# VACCINATOR'S MANUAL

## “Immunisation That Works”

Expanded Programme on Immunisation in  
South Africa (EPI-SA)



Love them, Protect them, Immunise them

4<sup>th</sup> Edition, October 2012



**health**

Department:  
Health  
REPUBLIC OF SOUTH AFRICA

This manual was published by:  
The National Department of Health

**Editorial Team:**

National EPI Team

UNICEF South Africa

WHO South Africa

Provincial EPI Coordinators

Provincial Cold Chain Coordinators

Communication and Request for copies may be addressed to:

The Expanded Programme on Immunisation (EPI)

National Department of Health

**Physical Address:**

8<sup>th</sup> Floor North Tower, Civitas Building

242 Struben Street, Corner -Thabo Sehume Street (previously Andries Str)

Pretoria, Central Business District

**Postal Address:**

Private Bag x 828

Pretoria

0001

Email: [Episa@health.gov.za](mailto:Episa@health.gov.za)

Tel no: +12 395 9531 \8915\ 8914\9025

Fax no: +12 395 8905/06

© Copyright 2012 National Department of Health

Any part of this material may be reproduced or copied without the permission of the National Department of Health, provided that the parts reproduced are unchanged and distributed free of charge or at cost – not for profit.

**Acknowledgements:**

The Department of Health would like to thank UNICEF South Africa for the significant contribution made towards this manual. The Department of Health is also grateful to WHO South Africa, EPI colleagues at provincial and district levels and many others who contributed to this manual.

## FOREWORD VACCINES MANUAL

Immunisation remains the most cost effective public health intervention available. As new underutilised vaccines are included in the immunisation schedule, the Expanded Programme on Immunisation (EPI) plays an increasing role in the control of vaccine preventable diseases (VPD's) and in reducing child mortality. It is for this reason that the international health community has directed more efforts at strengthening EPI as a key strategy for the attainment of Millennium Development Goals no. four (MDG 4) of reducing child mortality.

This 4<sup>th</sup> edition of the Vaccinator's Manual is well timed as it includes two new vaccines: pneumococcal conjugate vaccine -13 valent (PCV13) and rotavirus vaccine (RV). It also includes the newer formulation of diphtheria, tetanus, acellular pertussis, injectable polio and haemophilus influenzae type b (DTaP-IPV//Hib). It comes at a time when the World Health Assembly (WHA) has designated the period from 2011 to 2020 the "Decade of Vaccines". The vision of the "Decade of Vaccines" is to achieve universal access to immunisation with all lifesaving vaccines including new vaccines; uphold immunisation as a Human Right and establish immunisation as a core component of Primary Health Care. Its mission is to extend the full benefits of immunisation to all people by 2020 and beyond; regardless of where they are born, who they are and where they live.

These goals are in keeping with those of the Expanded Programme on Immunisation in South Africa (EPI-SA). EPI-SA aims to reach every child with quality immunisation services that incorporate the use of new vaccines and technology; and to ensure that no child is denied her/his right to protection against VPDs.

This edition provides health professionals with guidance to make a contribution to this noble goal. Every Health Professional who cares for children should be familiar with the contents of this manual. The manual should be used to control, eliminate and eradicate the targeted diseases and protect South Africa's children against vaccine preventable diseases.

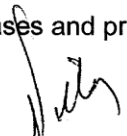
  
**MS MP MATSOSO**  
**DIRECTOR-GENERAL: HEALTH**  
Date: 29/11/12

<b>Table of Contents</b>	<b>Page No.</b>
<b>ACRONYMS .....</b>	<b>7</b>
<b>MODULE 1: INTRODUCTION AND EPI GOALS.....</b>	<b>9</b>
Overview Of This Module .....	9
Introduction To EPI-SA.....	11
<b>MODULE 2: EPI DISEASES AND VACCINES.....</b>	<b>14</b>
Description Of VPDS in EPI Schedule.....	14
Basics On Immunology.....	20
General Characteristics Of Vaccines And Classification .....	21
Brief Description Of Vaccines Used in EPI -SA .....	24
<b>MODULE 3: INTRODUCING NEW VACCINES .....</b>	<b>26</b>
Rotavirus Vaccine .....	26
Pneumococcal Conjugate Vaccine- 13 Valent (Pcv 13).....	30
DTaP-IPV//Hib Vaccine (Pentaxim): .....	31
<b>MODULE 4: SCHEDULE AND STRATEGIES FOR IMMUNISATION PRACTICES.....</b>	<b>33</b>
Routine Immunisation Schedule .....	33
Vaccination Of Pregnant Women .....	35
Special Immunisation Situations And HIV Infected Children .....	37
Immunisation For Other Cases .....	37
Catch Up: For Children Who Missed Scheduled Doses.....	39
<b>MODULE 5: PREPARING FOR AN IMMUNISATION SESSION .....</b>	<b>43</b>
<b>MODULE 6: THE COLD CHAIN - THE KEY TO POTENT VACCINES .....</b>	<b>54</b>
The Vaccine Fridge .....	55
<b>MODULE 7: THE TEMPERATURE MONITORING DEVICES .....</b>	<b>64</b>
The Temperature Monitoring Charts .....	65
Fridge Tags .....	65
The Vaccine Vial Monitor (VVM) .....	66
The Freeze Tag .....	68
<b>THE EPI-SA OPEN-MULTI-DOSE VIAL POLICY .....</b>	<b>70</b>

<b>MODULE 8: IMMUNISATION AND INJECTION SAFETY</b> .....	<b>72</b>
Background.....	72
Types Of Injection Equipment.....	74
<b>MODULE 9: ADVERSE EVENTS FOLLOWING IMMUNISATION (AEFIs)</b> .....	<b>83</b>
Background.....	83
Adverse Events Which Should Be Reported.....	84
Case Definitions And Management Of Specific AEFI.....	85
Surveillance For Adverse Events Following Immunisation (AEFI).....	90
Taking Action On Adverse Events Following Immunisation.....	101
<b>MODULE 10: SOCIAL MOBILISATION, ADVOCACY &amp; COMMUNICATION</b> .....	<b>107</b>
Background.....	107
Important Information On Risk-Benefit Communication: .....	109
<b>MODULE 11: EVALUATING YOUR IMMUNISATION PROGRAMME</b> .....	<b>111</b>
Service Evaluation .....	111
Monitoring Vaccination Coverage.....	112
EPI Data And Information Flow .....	113
<b>MODULE 12: SURVEILLANCE FOR EPI TARGETED DISEASE</b> .....	<b>115</b>
Definition And The Types Of Surveillance .....	115
Diseases For Elimination And Eradication.....	117
Effective EPI Disease Control .....	123
<b>MODULE 13: REACHING EVERY DISTRICT (RED) STRATEGY</b> .....	<b>125</b>
Background.....	125
Implementing The RED Strategy.....	126
<b>MODULE 14: SUPERVISION AT FACILITY LEVEL</b> .....	<b>135</b>
Background.....	135
Basic Principles Of Supervision .....	135
Organising The Work Of A Supervisor .....	136
EPI Red Flag Checklist.....	139
Regular Review Checklist.....	140
Quarterly Review Checklist - EPI In-Depth Programme Review.....	143

<b>APPENDIXES .....</b>	<b>147</b>
<b>Appendix 1: Characteristics And Important Points About EPI Vaccines .....</b>	<b>147</b>
<b>Appendix 2: Vaccine Stock Record .....</b>	<b>149</b>
<b>Appendix 3: Clinic Vaccine Ordering Form .....</b>	<b>150</b>
<b>Appendix 4: Daily Fridge Temperature Chart .....</b>	<b>151</b>
<b>Appendix 5 : Fridge Tag Temperature Chart.....</b>	<b>152</b>
<b>Appendix 6 : Fridge Tag User Manual .....</b>	<b>153</b>
<b>Appendix 7: Case Definitions for Surveillance of EPI Conditions.....</b>	<b>157</b>
<b>Appendix 8: Case Investigation Form (AEFI) .....</b>	<b>158</b>
<b>Appendix 9: Immunisation Monitoring Chart.....</b>	<b>160</b>
<b>Appendix 10: EPI-SA Integrated Communication Strategy Plan.....</b>	<b>162</b>
<b>Appendix 11: Health Facility Vaccination and Defaulter Tracing Register.....</b>	<b>163</b>

## ACRONYMS: EPI

AD	Auto-Disable
AEFI	Adverse Event Following Immunisation
AFP	Acute Flaccid Paralysis
AIDS	Acquired Immuno Deficiency Syndrome
ARCC	Africa Region Certification Commission
ARV	Anti-Retroviral Drugs
BCG	Bacillus Calmette Guerin (Anti-tuberculosis Vaccine)
B. pertussis	<i>Bordetella pertussis</i>
C. diphtheriae	<i>Corynebacterium diphtheriae</i>
CDC	Centre for Disease Control
CI	Contraindications
CIF	Case Investigation Form
CHC	Clinic Health Committee
C. tetani	<i>Clostridium tetani</i>
DHIS	District Health Information System
DHMT	District Health Management Team
DO	Drop Out
DTP-Hib	Diphtheria-Tetanus-acellular Pertussis Haemophilus Influenzae type b
DTaP-IPV//Hib	Diphtheria, tetanus, acellular pertussis, injectable polio and haemophilus influenzae type b
EDL	Essential Drugs List
EPI	Expanded Programme on Immunisation
EPI-SA	Expanded Programme on Immunisation in South Africa
FEFO	First to Expire, First Out
FHA	Filamentous Haemagglutinin
FI	Fully Immunised
GIVS	Global Immunisation Vision and Strategy
GSK	GlaxoSmithKline
HBc Ag	Hepatitis B core Antigen
HBe Ag	Hepatitis B e Antigen
HBs Ag	Hepatitis B surface Antigen
HBV	Hepatitis B Virus
Hep B	Hepatitis B Vaccine
HHE	Hypotonic Hyporesponsive Episode
Hib	<i>Haemophilus influenzae type b</i>
HIV	Human Immunodeficiency Virus



IDS	Integrated Disease Surveillance
IG	Immunoglobulin
IM	Intra-Muscular
IMCI	Integrated Management of Childhood Illnesses
IPV	Inactive Polio Vaccine
MCV	Measles vaccine
MDG	Millennium Development Goal
MDR-TB	Multi-Drug Resistant Tuberculosis
MSD	Merck Sharp and Dohme
M. tuberculosis	<i>Mycobacterium tuberculosis</i>
NHLS	National Health Laboratory Services
NICD	National Institute for Communicable Diseases
NNT	Neonatal Tetanus
OPV	Oral Polio Vaccine
ORT	Oral Rehydration Therapy
PCV	Pneumococcal Conjugate Vaccine
PHC	Primary Health Care
PT	Pertussis toxin
RED	Reach Every District
RNA	Ribonucleic acid
RTHC	Road to Health Card
RV	Rotavirus Vaccine
SCID	Severe Combined Immunodeficiency Disorder
SMC	Suspected Measles Case
TB	Tuberculosis
Td	Tetanus & reduced strength diphtheria vaccine
TOPV	Trivalent Oral Polio Vaccine
TSS	Toxic Shock Syndrome
TT	Tetanus Toxoid
UNICEF	United Nations Children's Fund
VAPP	Vaccine Associated Paralytic Polio
VPD	Vaccine Preventable Disease
VVM	Vaccine Vial Monitor
WHA	World Health Assembly
WHO	World Health Organisation
XDR	Extensive Drug Resistant

## MODULE 1: INTRODUCTION AND EPI GOALS

---

### OVERVIEW OF THIS MODULE

This module introduces the “*Vaccinator’s Manual*”, a *guideline for vaccinators*. The aim of the manual is to update EPI guidelines to include all the changes since the third edition of the *Vaccinators Manual (2008)*.

There have been significant changes in EPI schedule since the last edition; particularly with the introduction of new vaccines, namely: rotavirus, pneumococcal vaccines and the inactivated polio vaccine. There are changes in the combination of one of the vaccines, the shift from DTP-Hib to DTaP-IPV//Hib. This manual reflects these changes and incorporates the new vaccines into the routine EPI schedule.

Increasing and maintaining high immunisation coverage remains a challenge. Nearly 30% of districts did not reach the minimum target of 80% coverage for fully immunised children below 1 year in 2011. Over and above the need to increase routine immunisation coverage, the other priorities of the programme are: the control of measles and prevention of outbreaks, achieving and maintaining the required certification surveillance standard for Acute Flaccid Paralysis (AFP) and maintaining the elimination status of neonatal tetanus.

Although immunisation remains the most cost-effective public health intervention currently available, EPI has to compete with other priority health programmes for resources. Vaccinators and other health workers can be important advocates for the EPI.

#### **Aim of this manual**

This manual is intended to:

- Provide policy guidelines
- Set standards on immunisation practices
- Address practical issues that the vaccinator normally faces

The manual contains a set of sub-sections called “modules”. Each module covers a specific topic.

### **What is new in this manual?**

The manual includes changes made to policies relating to the EPI program. These are:

- The addition of inactivated polio vaccine (IPV) while maintaining the birth and 6 week doses of OPV
- The introduction of rotavirus vaccine at 6 and 14 weeks
- The introduction of pneumococcal conjugate vaccine at 6 weeks, 14 weeks and 9 months
- The switchover from the quadrivalent DTP-Hib to the pentavalent DTaP-IPV//Hib vaccine which contains the acellular form of pertussis vaccine and IPV.

One additional module on new vaccines has been incorporated to include more information on the new vaccines.

## INTRODUCTION TO EPI-SA

Immunisation is the most precious gift that a health care worker can give a child.

The purpose of the Expanded Programme on Immunisation in South Africa (EPI-SA) is to prevent death and reduce suffering from diseases of childhood that can be prevented by immunisation of children and women. Immunisation against these diseases; (measles, polio, diphtheria, whooping cough (pertussis), tetanus, hepatitis B, haemophilus influenzae type b (Hib), tuberculosis, pneumococcal diseases and diarrhoea caused by rotavirus), remains the most cost effective public health intervention currently available. Health workers involved in immunisation are in a privileged position to ensure this protection.

In line with the principles of Global Immunisation Vision and Strategies (GIVS), EPI-SA has taken the lead in the African region in introducing new vaccines in an effort to provide additional protection for children from some of the common causes of morbidity and mortality. Vaccines against rotavirus diarrhoea and pneumococcal infections have been added to the EPI schedule. Moreover, the shift from DTP-Hib to the DTaP-IPV//Hib provides an opportunity to use the safer forms of polio and pertussis vaccines.

EPI is an essential part of a comprehensive Primary Health Care (PHC) package. The main target population for EPI is children who are 13 years and younger and pregnant women. The recent strengthening of school health services and the re-engineering of primary health care services provides an ideal opportunity to increase the coverage of vaccines like Td that are given to the school going age group.

Through the years EPI-SA has achieved most of its set goals and made significant progress as highlighted below.

## Some Significant Achievements of EPI-SA.

- Early and timely introduction of new and underutilised vaccines
- Progress in Polio Eradication is as follows:
  - In 2006 SA was declared to have interrupted the transmission of wild poliovirus and declared “Polio Free” by the Africa Region Certification Commission (ARCC)
  - A well established active AFP surveillance system is in place,
  - All 3 committees for Polio Eradication and Certification are functioning
  - Certification standard AFP surveillance was reached in 2003 and has been maintained since then.
- Neonatal tetanus (NNT) has been eliminated. A Neonatal Tetanus (NNT) Validation conducted in 2002, confirmed that South Africa has eliminated NNT.
- South Africa has revised Tetanus Toxoid (TT) policy, which is now being implemented to ensure that South Africa maintains the elimination status.
- EPI-SA is monitored through the District Health Information System (DHIS). EPI is thus able to access the routine immunisation coverage data.

### Revised EPI goals, 2011

- Achieve fully immunised coverage for children below 1 year of at least 90% at national level and 80% in all districts by the year 2015
- Maintain Polio Free status until polio eradication is achieved globally
- Maintain Neonatal Tetanus elimination status
- Achieve measles pre-elimination goals by 2015
- Investigate and respond to 80% of suspected adverse events following immunisation

Although these goals are set at national level, they can only be achieved through the implementation of effective programmes at provincial and district levels. Hence provinces and districts have the responsibility to ensure the attainment of these goals. All provinces and districts need to adopt these goals and set out strategies and operational plans to achieve the set targets. The World Health Organization (WHO) recommends the implementation of the Reach Every District (RED) strategy to realize these goals. EPI-SA adopted the RED strategy in 2006 and started the implementation.

Module 13 describes the basic principles of the RED strategy.

### **Important points about the EPI goals**

- ❑ The EPI goals should be considered when drawing annual operational plans.
- ❑ Provinces, districts, sub–districts and facilities, should set their goals and appropriate indicators in line with the national EPI goals.
- ❑ Appropriate targets and performance indicators that are required to achieve the EPI goals should be set at provincial, district and facility levels.
- ❑ Annual operational plans should indicate time schedule for completion of activities, persons responsible for the tasks and specify the allocated funds.
- ❑ Provincial EPI goals and operational plans should be communicated to districts and facilities.
- ❑ Districts and provinces should use their current performance on EPI coverage and targeted disease surveillance to set goals and compile plans for EPI.

### **Provision of immunisation services: EPI-SA policy**

Immunisation services for children and women should as far as possible be available at all public health facilities (clinics, hospitals and community health centres), as part of the free health services for women and children (under 6 years).

EPI-SA supports private sector participation in EPI, with emphasis on the administration of EPI vaccines under safe and appropriate conditions and the detection & reporting of the EPI targeted diseases including adverse events following immunisation (AEFI). EPI also emphasises that Every Day should be an Immunisation Day in all health facilities.

## MODULE 2: EPI DISEASES AND VACCINES

---

### DESCRIPTION OF VACCINE PREVENTABLE DISEASES IN THE EPI SCHEDULE

EPI-SA provides immunisation against ten vaccine-preventable diseases. It distinguishes between two groups namely; the EPI Diseases Targeted for elimination and eradication and other vaccine preventable EPI diseases as follows:

The EPI diseases targeted for elimination and eradication:

- Poliomyelitis
- Measles
- Neonatal Tetanus (NNT)

These are of highest priority and national systems for case based surveillance with laboratory support are in place for this purpose.

Other EPI diseases:

- Diphtheria
- Pertussis
- Tuberculosis
- Hepatitis B
- Haemophilus Influenzae type b (Hib)
- Rotavirus
- Pneumococcal infections

The programme aims to reduce the burden of vaccine preventable diseases (VPDs) and associated mortality. The long term objective is to control and eventually eliminate some of the VPDs included in the EPI schedule. Some of these diseases are already targets for elimination or eradication (Polio, Measles, and NNT). Module 10 of this handbook contains detailed information about EPI Target Disease Surveillance. More information can also be found in the *EPI Disease Surveillance Field Guide, 2012*.

A brief description and information on each condition (disease) in the EPI schedule follows.

## **Diphtheria**

A bacterial infection caused by *Corynebacterium diphtheriae* (*C. diphtheriae*), an aerobic gram-positive bacillus. Transmission is from person to person and takes place through close physical and respiratory contact. It presents as an acute disease of tonsils, pharynx, larynx, nose and occasionally other mucous membrane or skin. The organism produces a cytotoxin that inhibits cellular protein synthesis and is responsible for local tissue destruction and membrane formation. The characteristic lesion is a patch or patches of an adherent greyish membrane with surrounding inflammation in the fauces (throat). The throat is sore, with enlarged and tender cervical lymph nodes. In severe cases there is swelling and oedema of the neck with extensive membrane formation that may result in respiratory obstruction.

Laryngeal diphtheria is a serious infection, particularly in infants and young children. Another diphtheria condition is cutaneous diphtheria, which is rare but more common in tropical countries. The lesions are variable and may be similar to impetigo.

Before vaccination, diphtheria commonly affected pre-school and school age children. Deaths occurred from respiratory obstruction from the membrane or exotoxin-induced damage to organs. Many cases of diphtheria infection are asymptomatic.

## **Haemophilus Influenzae type b (Hib)**

This is an aerobic, gram-negative bacterium with a polysaccharide capsule. There are six different sero - types of haemophilus influenzae (a-f), but type b causes 95% of invasive diseases. The organism enters the body through the nasopharynx where organisms colonise and may remain only transiently or for several months in the absence of symptoms in so-called asymptomatic carriers.

The bacteria spread in the bloodstream to distant sites in the body, and is likely to affect the meninges. The most common types of invasive disease are meningitis, epiglottitis, pneumonia, arthritis and cellulitis. The majority of serious Hib infections occur in children under five years. Two-thirds of cases occur amongst children below 2 years.



## Hepatitis B

The hepatitis B virus (HBV) causes acute hepatitis B disease. Three of the HBV antigens are crucial in diagnosis and in epidemiology. These are hepatitis B surface antigens (*HBs Ag*) that form part of the virus coat, the core antigen (*HBc Ag*) and the e antigen (*HBe Ag*), a conformational variant of the core antigen, which indicates high infectivity.

Acute infection is usually sub-clinical in infants and young children, but leads to malaise, nausea, and jaundice in older persons. The main public health importance relates to chronic liver disease and liver cancer that may result from HBV infection. The risk of becoming a chronic carrier increases significantly when infection occurs at a younger age.

In Sub-Saharan Africa, most transmission occurs after birth during the first year of life due to horizontal transmission, in the form of person to person spread from close contact. Perinatal or “vertical transmission” may also occur from a carrier mother (more likely if the mother is HBe Ag-positive). Hepatitis B transmission also occurs through sexual intercourse and through contact with infected blood; for example, blood transfusion and needle sharing among intravenous drug users.

Health care workers are particularly at risk of contracting Hepatitis B through needle stick injuries and through contact with body fluids.

## Measles

Measles virus is an RNA virus, a member of the genus *Morbilivirus* in the family *Paramyxoviridae*. The measles virus leads to an acute viral infection that is transmitted by close respiratory contact. Measles is also spread via aerosolised droplets, for example in school corridors. Measles can have serious complications which include; pneumonia, diarrhoea, otitis media, encephalitis, blindness and death. Under-nutrition and Vitamin A deficiency increases the risk of developing measles complications. Most deaths occur from secondary infections of the respiratory and/or gastrointestinal tract.

## Tetanus

Tetanus is an acute disease caused by a neurotoxin produced during the growth of the anaerobic bacterium, *Clostridium tetani* (*C.tetani*). The organism may be present in dead tissues such as dirty wounds or the umbilical cord stump of babies born at home deliveries and where traditional practices include application of cow-dung or similar stuff to the

umbilical stump. There is no human to human transmission. The tetanus spores form part of normal flora in the guts of animals; like cattle, sheep and goats, thus the organism is ubiquitous (everywhere) in the environment. It is for this reason that tetanus, as a condition cannot be eradicated.

## **Tuberculosis**

Tuberculosis is a disease caused by *Mycobacterium tuberculosis* (*M. tuberculosis*), a strictly aerobic, non-motile rod with complex, lipid-rich cell walls resisting removal of stain by acid alcohol (hence “acid fast”).

The HIV pandemic has resulted in a significant increase in TB cases and multi-drug-resistant tuberculosis, causing TB to be a serious public health problem. According to WHO estimates there were 9.4 million new TB cases in 2009, including 1.1 million cases among people with HIV and 1.7 million people died from TB including 380 000 people with HIV. It was estimated that in 2009, 3.3% of all new TB cases had MDR-TB.

## **Pertussis**

Pertussis or whooping cough is an acute bacterial infection involving the respiratory tract. It is caused by *Bordetella pertussis* (*B. pertussis*). The initial catarrhal stage has an insidious onset with an irritating cough, which gradually becomes paroxysmal within 1 or 2 weeks and lasts 1 to 2 months. The paroxysms are characterized by repeated violent coughs; each series has many coughs with no inhalation in between the coughs and may be followed by a characteristic whoop. In severe cases there is associated cyanosis and vomiting. In young infants, apnoea may be the presenting symptom.

Transmission is through contact with discharges from respiratory mucous membranes of infected persons and is also airborne by droplet spread. The infection is frequently brought home by an older sibling.

Despite the relatively high immunisation coverage level, pertussis cases continue to occur, and may include adults.

## **Poliomyelitis**

Polio is a highly infectious disease caused by poliovirus and most commonly affects children under the age of 5. However, a person of any age who does not have immunity against polio may be infected. Polioviruses are ribonucleic acid (RNA) viruses that belong to the enterovirus family of the picornavirus group. There are three types of poliovirus namely type 1, 2 and 3. Poliovirus only infects human beings.

Prior to the Polio Eradication Initiative, polio occurred all over the world, but mainly affected developing countries. It is seasonal; occurring more commonly during the summer in countries with a temperate climate, and during the rainy season in countries with a tropical climate. The major route of poliovirus transmission is faeco-oral and direct personal contact through close association with an infected individual. The virus spreads from person to person by contaminated hands and food in areas with poor sanitation.

Crowded living conditions, poor sanitation and areas with low immunisation coverage increase the risk of poliovirus transmission. Up to 95% and more of poliovirus infections are asymptomatic (show no symptoms or signs), therefore many will be infected but will not develop paralysis. The risk of paralysis in infants and in children under 15 years of age ranges from 1 in 100 to 1 in 500 infections.

Risk factors that are known to increase the likelihood of paralysis include; the administration of injections, tonsillectomy, pregnancy, stress, and trauma during the incubation period of poliovirus infection.

## **Diseases caused by *Streptococcus Pneumoniae* or Pneumococcus**

*Streptococcus pneumoniae* or Pneumococcus is a gram positive, encapsulated diplococcus that is part of the normal flora of the human nasopharynx. There are over 90 serotypes of pneumococcus, but only about 23 serotypes are responsible for over 90% of the infections. Immunity to pneumococcal infection is type specific.

Pneumococcal disease ranges from serious illnesses like pneumonia, bacteraemia and meningitis to less serious manifestations like otitis media and sinusitis. Pneumococcus is the most common bacterial cause of pneumonia and the major bacterial cause of meningitis in children. It is a major cause of mortality and morbidity particularly in children. In 2005 the WHO estimated about 1.6 million people die of pneumococcal diseases every year that includes the deaths of 0.7-1 million children below 5 years, most of whom live in developing

countries. Major risk factors for infection include: young age (age <5; particularly age <2); underlying immunodeficiency or other underlying illnesses (like sickle cell disease, nephrotic syndrome, cancer); day care attendance; old age; alcoholics; lack of breastfeeding; and exposure to tobacco smoke.

The mode of transmission is by droplet spread and by direct contact or indirectly through articles that are soiled with respiratory discharges. Early aetiological diagnosis is important for treatment. However, failure to isolate the organism often results from the prior use of antibiotic treatment, the improper handling and transport of specimens and the use of inappropriate culture

The development of resistance of the organism to commonly used antibiotics has over the years posed a treatment challenge. The use of the pneumococcal conjugate vaccine (PCV) is the best approach to the control of this condition, for both the immune-suppressed and immune-competent children.

### **Rotavirus infection**

Rotaviruses are RNA viruses classified as a genus in the family of *Reoviridae*. Although the viral strains show considerable diversity, 5 serotypes are responsible for the majority of human rotavirus disease. Rotaviruses are the most common cause of severe diarrhoeal disease in infants and young children worldwide. In 2004, WHO estimated that rotavirus infections cause approximately 527 000 (475 000–580 000) deaths, predominantly in developing countries where three-quarters of children acquire their first episode of rotavirus diarrhoea before the age of 12 months. Severe rotavirus gastroenteritis is largely limited to children aged 6–24 months.

Rotaviruses are shed in very high concentrations and for many days in the stools and vomitus of infected individuals. Transmission occurs primarily by the faeco–oral route, directly from person to person or indirectly via contaminated articles.

**Poliomyelitis, Measles and Neonatal Tetanus (NNT) are the three EPI-SA target diseases with case based surveillance and laboratory support systems in place. Sentinel surveillance is conducted for Hib, rotavirus and pneumococcal infections.**

## BASICS ON IMMUNOLOGY

Immunity refers to “protection from infectious diseases”. It is the ability of the human body to tolerate the presence of material indigenous to the body (“self”), and to eliminate foreign (“non-self”) material. Immunity is generally specific to a single organism or group of closely related organisms.

There are two basic mechanisms through which one acquires immunity; passive and active.

**Passive immunity** is protection by introduction of protective antibodies into the human being usually by injection of immunoglobulins (IG) or transfer of antibodies from one human being to another e.g. transfer of maternal antibodies to an infant. Passive immunity often provides effective protection, however this protection is not long lasting and usually wanes (disappears) with time.

**Active immunity** is protection which is produced by the person’s own immune system as a result of a challenge by an antigen, either as a natural infection or through vaccination (immunisation). This type of immunity is generally long lasting and often lifelong.

### Points to remember about immunity:

- The immune system is a complex system of interacting cells whose primary purpose is to identify foreign (“non-self”) substances, which we refer to as antigens (usually live micro-organisms) and develop a defence against them.
- This defence is known as the *immune response* and usually involves the production of protein molecules, called *antibodies* (or immunoglobulins) and specific cells, whose purpose is to facilitate the destruction of the foreign substance (an *antigen*).
- A live antigen produces the most effective immune response. However, an antigen does not necessarily have to be live, as in a natural infection with a virus or bacteria, to produce an immune response.
- The immune system recognises some proteins easily, such as hepatitis B surface antigen. Other materials such as polysaccharides (long chains of sugar molecules, which make up the cell wall of certain bacteria) are less effective antigens, thus the immune response against these may not be optimal.

- An immune response is generally very specific to the organism or antigen that produced it. For example, antibodies produced in response to measles virus have no effect on rubella or influenza viruses.
- The natural disease or administrations of a vaccine are the two ways to acquire active immunity. The natural disease usually provides lifelong immunity, which is mediated through production of memory cells of the immune system.
- The production of memory cells and the process of long term or lifelong protection are similar to that of the natural disease. The immune system does not differentiate between an infection with a weakened vaccine virus and an infection with a wild virus.

#### **Important factors that may influence the immune response to vaccination:**

- Presence of maternal antibodies
- Nature and dose of the antigen
- Route of administration of the vaccine
- Host factors such as age, nutritional status, genetics and co-existing disease

### **GENERAL CHARACTERISTICS OF VACCINES AND CLASSIFICATION**

Vaccines are biological substances that interact with a person's immune system to produce an immune response identical to that produced by natural infection. Immunisation protects not just the individual vaccinated, it also protects communities. When vaccination coverage levels in a community are high enough, protection of the few unvaccinated persons is indirectly achieved because the large number of protected individuals prevents transmission of that particular infectious agent. This is referred to as **herd immunity**. The few unvaccinated individuals living among vaccinated persons receive protection from exposure to the disease, through herd immunity.

The specific characteristics that differentiate each type of vaccine also determine the way in which that vaccine is used. For example, the timing and spacing of vaccine doses is one of the most important factors in the appropriate use of vaccines.

The purpose of vaccination is to stimulate the recipient's immune system to produce its own antibodies without going through the natural infection.

There are two main groups for the classification of vaccines:

- Live attenuated vaccines
- Inactivated vaccines

Production of *live attenuated* vaccines takes place through a process of modification of disease-producing “wild” virus or bacteria in a laboratory. The vaccine organism retains the ability to grow and produce immunity, but does not cause the disease.

When a live attenuated vaccine does cause “disease”, it is usually milder than the natural disease and considered as a reaction to immunisation or an adverse event.

The more similar a vaccine is to the natural disease, the better the immune response to that disease.

The advantage of a live attenuated vaccine is that it produces almost the same immunity as natural infection because the immune system does not differentiate between infection with a weakened vaccine virus/bacterium and wild infection.

Production of *inactivated vaccines* takes place by growing bacteria or virus in culture media, followed by inactivation with heat or chemicals or both. For fractional vaccines, further purification of the organism takes place to retain only the components that will be included in the vaccine, for example, the polysaccharide capsule of pneumococcus.

Inactivated vaccines require multiple doses. The first dose does not produce protective immunity but only “primes” the immune system. A protective immune response develops after a second or third dose. The components of inactivated vaccines are not live and therefore cannot cause disease. The antibody levels against inactivated vaccines wane over time and therefore some inactivated vaccines may require periodic booster doses.

**Table 2.1: Current available attenuated and inactivated vaccines**

<b>Classification</b>	<b>Sub-class</b>	<b>EPI Vaccine</b>	<b>Other Vaccines</b>
<b>Live attenuated vaccines</b>	• Live attenuated virus vaccines	Measles, oral polio vaccine, Rotavirus vaccine	Mumps, rubella, yellow fever, varicella
	• Live bacterial vaccines	BCG	
	• Live recombinant bacterial vaccine		Oral typhoid
<b>Inactivated vaccines</b>	• Inactivated whole viruses	Injectable polio vaccine	Hepatitis A, influenza and rabies
	• Inactivated whole bacteria	Pertussis	Cholera, typhoid and plague
	• Fractional vaccines	Sub-units such as Hepatitis B	Sub-units such as influenza and acellular pertussis
	• Toxoid	Diphtheria, tetanus	Botulinum
	• Polysaccharides		Meningococcal
	• Polysaccharide conjugates	<b>Haemophilus Influenzae type b (Hib), Pnemococcal vaccines</b>	

**Did you know?**

...that immunisation is a triangle between the Vaccinator, the Vaccines and the Vaccinee. The Vaccinator is the health worker who provides immunisation services and who ADMINISTERS THE vaccines. The Vaccines are special biologicals, very different from any other drug in a health facility. The Vaccinee is the most precious group – they are the children and women and the target group to receive the vaccines!



## BRIEF DESCRIPTION OF VACCINES USED IN EPI-SA

**BCG vaccine** is a live bacterial vaccine and comes in powder form. It must be reconstituted with a diluent before use. It is essential that only the diluent supplied with the vaccine is used. BCG should be kept at 2°C – 8°C after reconstitution. Any remaining reconstituted vaccine must be discarded after six hours or at the end of the immunisation session, whichever comes first.

**Oral polio vaccine (OPV)** is a trivalent live attenuated vaccine containing antigens of all the three types of poliovirus. It is a liquid vaccine that is provided in two types of containers either with small plastic dropper bottles or glass vials with droppers in a separate plastic bag. The vaccine is also kept at 2°C–8°C before use. It is not damaged by freezing.

**The Rotavirus vaccine** is a live attenuated human rotavirus strain, presented as 1.5 ml suspension for oral administration. The vaccine should be protected from direct sunlight and stored in a refrigerator (2–8 °C) and should not be frozen. It is presented as a clear, colourless liquid, free of visible particles, for oral administration. It is available in a squeezable tube fitted with a nozzle and cap in pack sizes of 1 or 10. The vaccine is ready to use (no reconstitution or dilution is required).

**Pneumococcal Conjugate Vaccine -13 valent (PCV<sub>13</sub>)** is a conjugate vaccine. Each 0.5 ml dose contains capsular poly/oligosaccharides of 13 serotypes, conjugated to the non-toxic protein and adsorbed onto aluminium phosphate to enhance the antibody response. It does not tolerate freezing and should be stored at 2–8 °C. The current presentation of PCV-13 is in single-dose, pre-filled syringes in 1-dose or 10-dose packages.

**DTaP-IPV//Hib** is combination of Diphtheria toxoid, Tetanus toxoid, acellular Pertussis vaccine, Inactivated Polio Vaccine with a freeze-dried powder conjugate of *Haemophilus influenzae* type b vaccine (Hib). Hib conjugate vaccine is presented as a white, homogenous powder while the acellular component of pertussis vaccine is combined with diphtheria and tetanus toxoids and injectable polio vaccine is in a form of whitish turbid suspension for injection. The vaccine must be injected immediately after reconstitution of the freeze-dried powder by the suspension. DTaP-IPV//Hib vaccine should never be frozen and should be stored at a temperature between +2°C and +8°C.

**Hepatitis B (Hep. B)** vaccine is a cloudy liquid that is provided in single- or multi-dose vials. If Hep. B vaccine stands for a long time, the vaccine may separate from the liquid. When separated, the vaccine looks like fine sand at the bottom of the vial. Shake the vial to mix the vaccine and liquid before using the vaccine. Hep. B vaccine should never be frozen. The “Shake test” will determine if freezing has damaged the vaccine. If the vaccine fails the shake test you must discard it.

**Measles vaccine** is provided as a powder, with a diluent in a separate vial. It must be reconstituted before use. It is essential that only the diluent supplied with the vaccine is used. After reconstitution, measles vaccine should be kept at 2°C – 8°C. Any remaining reconstituted vaccine must be discarded after six hours or at the end of the immunisation session, whichever comes first.

**Hib conjugate vaccines** are available in several different formulations. They can be obtained as a liquid or freeze-dried powder (lyophilized), in single or multi-dose vials, and as monovalent vaccines (Hib conjugate vaccine only) or in combination with other routine vaccines (e.g. DTP, DTP-hepatitis B or DTaP-IPV//Hib). EPI-SA has shifted to the use of DTaP-IPV//Hib in its routine immunisation programme.

## MODULE 3: INTRODUCING NEW VACCINES

---

In this module a brief description of the newly introduced vaccines namely, Rotavirus vaccine, Pneumococcal vaccine and the combined Diphtheria-Tetanus-acellular Pertussis-Inactivated Polio-Haemophilus influenzae type b (DTaP-IPV//Hib) is presented.

Module 4 has the new revised schedule (including these vaccines) and the guide on Catch-Up vaccination for children who missed one or more vaccines. Hence the reader is referred to Module 4 for EPI schedule in South Africa.

### ROTAVIRUS VACCINE

**Background:** Rotavirus is the most common cause of severe diarrhoea in young children. It can result in acute dehydration, vomiting, and fever. It is responsible for more than half a million deaths each year among children below the age of five years.

Although in the past 20 years, improvements in sanitation and use of oral rehydration therapy (ORT) have significantly reduced diarrhoea mortality; vaccination provides the means to prevent severe rotavirus disease. Vaccines are an important new addition to the interventions in the prevention and management of diarrhoeal disease.

The World Health Organization (WHO) licensed two vaccines against rotavirus in 2006: Rotarix, manufactured by GlaxoSmithKline (GSK) and RotaTeq, manufactured by Merck Sharp and Dohme (MSD). Clinical trials in many countries demonstrated their safety and high efficacy in preventing rotavirus associated severe gastroenteritis. A number of countries have licensed and introduced these vaccines

WHO granted prequalification to Rotarix in early 2007, designating it acceptable for procurement by United Nations agencies. A large randomized, placebo-controlled trial of Rotarix was conducted in South Africa where the vaccine was administered together with oral poliovirus vaccine (OPV) and other vaccines from the Expanded Programme on Immunisation (EPI). HIV-positive infants were not excluded and breastfeeding was not restricted. This study in South Africa showed 76.9% vaccine efficacy against severe rotavirus diarrhoea while in other countries in Asia efficacy as high as 96.1% was reported. MSD has also conducted similar large studies of RotaTeq in countries with settings that are similar to South Africa.

## **The monovalent human rotavirus vaccine (Rotarix™)**

South Africa introduced the monovalent human rotavirus vaccine (Rotarix) for use in routine EPI in 2009 in all the provinces. It is a live oral vaccine originating from a G1P strain that was isolated from a case of infantile gastroenteritis. This strain has undergone multiple passages in tissue culture, and the resulting attenuated vaccine strain. After extensive tests in many countries the vaccine was found to be safe and not associated with an increased risk of intussusception.

Studies have demonstrated that simultaneous administration of rotavirus vaccines and other vaccines including oral poliovirus vaccine does not interfere with the protective immune response of these vaccines and of rotavirus vaccine. Hence, ROTARIX can be given concomitantly with any of the following monovalent or combination vaccines OPV, (DTaP-IPV//Hib), hepatitis B (Hep. B) vaccine and pneumococcal conjugate vaccine.

There is no evidence that breastfeeding interferes with immune response to the vaccines, hence breastfeeding should continue before and after rotavirus vaccination.

The rotavirus vaccine does not protect against diarrhoea caused by other agents. Rotavirus vaccines should not be administered to children older than 24 weeks or 6 months.

**Contraindications:** Rotavirus vaccine should not be administered in:

- Infants who are hypersensitive to rotavirus vaccine or to any ingredient in the formulation.
- Infants who experienced hypersensitivity after previous administration of rotavirus vaccines.
- Infants with uncorrected congenital malformation of the gastrointestinal tract (such as Meckel's Diverticulum) that would predispose for intussusception.
- Subjects with Severe Combined Immunodeficiency Disorder (SCID)
- Infants who have a history of intussusception (severe abdominal pain, persistent vomiting, bloody stools, abdominal bloating and/or high fever).

### **Dose and interval between doses:**

The rotavirus vaccination schedule in South Africa consists of two doses administered at the ages of 6 and 14 weeks. The vaccine may be given to preterm infants following the same schedule, when the preterm infant turns 6 and 14 weeks. A minimum interval of 4

weeks should be kept. Rotavirus vaccine should not be administered after 24 weeks. Rotavirus vaccine is available as a 1.5 ml one-dose oral suspension for oral administration. If a child spits do not repeat the dose.

**Storage and Stability:** the vaccines should be stored in a refrigerator (2°C to 8°C). **Do not freeze** and protect from light.

**Vaccine handling:**

- The vaccine is presented as a clear, colourless liquid, free of visible particles, for oral administration.
- The vaccine is ready to use (no reconstitution or dilution is required).
- The vaccine is to be administered orally without mixing with any other vaccines or solutions.
- The vaccine should be inspected visually for any foreign particulate matter and/or abnormal physical appearance prior to administration. In the event of either being observed, discard the vaccine.

**Dosage Forms and Packaging**

ROTARIX vaccine is available as an oral suspension (1.5 ml) in a squeezable tube fitted with a nozzle and cap in pack sizes of 1 or 10.

**Figure 1. Administration of Rotavirus vaccine**

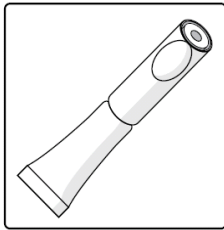

The tube form of rotavirus vaccine

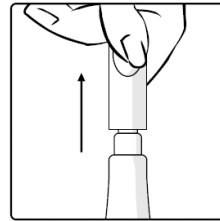

1. Pull off the cap from the top of the tube

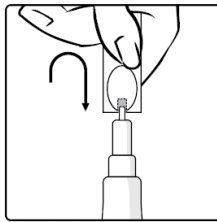

2. Turn the cap upside-down; replace the cap vertically over the nozzle as shown.

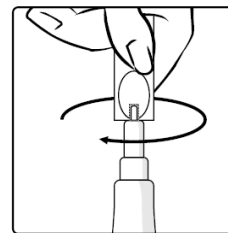

3. Twist the cap to remove the nozzle (do not snap it off) to leave a clean hole through which the vaccine can be expelled from the tube.

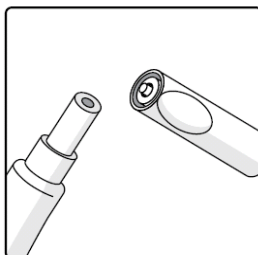

4. Ensure that the nozzle has been properly removed. A hole should clearly appear at the top of the tube and the nozzle should be inside the top of the tube's cap. In the unlikely event that the nozzle falls into the tube, discard the vaccine.

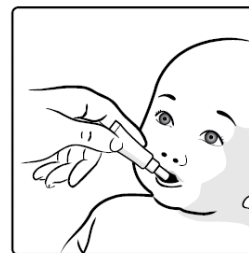

5. This vaccine is for **oral administration only**. The child should be seated in a reclining position. Administer **orally** (i.e. into the child's mouth towards the inner cheek) the entire content of the tube by gently squeezing the tube several times. A residual drop may remain in the tip of the tube.

## **PNEUMOCOCCAL CONJUGATE VACCINE- 13 VALENT (PCV 13)**

### **Background:**

*Streptococcus pneumoniae* (*S. pneumoniae*) is a major cause of illness and death in children and adults worldwide. Despite its importance, information on the burden of different forms of pneumococcal disease is limited.

According to a 2007 WHO estimate, about 800 000 children die each year from pneumococcal disease. About 90% of these deaths occur in developing countries. The groups at increased risk for pneumococcal disease include people with functional or anatomical asplenia (without a spleen); chronic diseases of the heart, lung, liver or kidneys; diabetes mellitus; alcoholism; cerebrospinal fluid leakage; congenital or acquired immunodeficiency (including HIV); haematological or generalized malignancies; those receiving immunosuppressive therapy, including systemic corticosteroids; and recipients of organ or haematopoietic cell transplantation or cochlear implants.

Bacteraemic pneumonia, febrile bacteraemia and meningitis are the major forms of invasive pneumococcal infection. Pneumococci are also believed to be a frequent cause of non-bacteraemic pneumonia, which in many developing countries may account for the majority of pneumococcal deaths. Middle-ear infection and sinusitis represent less severe but considerably more common non-invasive manifestations of pneumococcal infection.

### **The vaccine:**

The 13 valent Pneumococcal conjugate vaccine is one of the latest vaccines to be licensed for use in the fight against pneumococcal infections. It contains the saccharides of the capsules of the 13 sero types of pneumococcus conjugated to a non-toxic Diphtheria protein and adsorbed onto aluminum phosphate to enhance the antibody response. It contains all the antigens in the 7-valent vaccine (4,6B,9V,14,18C,19F,23F) and 6 additional important serotypes (1,3,5,6A,7F,19A). The 13 serotypes are responsible for the majority of pneumococcal infections.

**Indications:** prevention of pneumococcal disease caused by the 13 strains in the vaccine.

**Contraindications:** hypersensitivity to previous pneumococcal and diphtheria vaccine. Mild upper respiratory tract infections are not contraindications; but vaccination should be postponed in patients with severe febrile illness.

**Interaction with other vaccines:**

In South Africa the PCV13 injectable vaccine is used. The PCV 13 vaccine is given at the same time with diphtheria, tetanus, acellular pertussis, Hib, inactivated polio vaccine, hepatitis B at 6 and 14 weeks and with measles at 9 months. It can be given with other vaccines like rubella and whole cell pertussis.

**Dosage and administration:** the vaccine is given 0.5 ml intramuscularly either on the antero-lateral aspect of the right thigh in infants below 1 year or the deltoid muscle in older children. The vaccine should not be mixed with other vaccines in the same syringe and it should be given at a different injection site from other vaccines given at the same visit. The EPI-SA schedule has three doses are given at the ages of 6 weeks, 14 weeks and 9 months. (Refer module 4)

**Presentation:** is supplied as 0.5 ml transparent pre-filled glass syringe in a pack size of 1 and 10. This presentation requires substantially increased capacity in the cold chain.

**Storage:** the vaccine must be stored in 2-8<sup>0</sup>C. **DO NOT FREEZE**

**DTAP-IPV//HIB VACCINE (PENTAXIM):**

This is a combination vaccine including 5 antigens. It is indicated for active immunisation against diphtheria, tetanus, pertussis, poliomyelitis and invasive infections caused by *Haemophilus influenzae* type b (Hib), such as meningitis, septicaemia, cellulitis, arthritis, epiglottitis, pneumonia and osteomyelitis. The vaccine contains acellular pertussis and inactivated polio vaccine, both of which have been found to be effective and have a better side effect profile.

Acellular pertussis vaccines contain inactivated pertussis toxin (PT) and may contain one or more other bacterial components (e.g., filamentous haemagglutinin [FHA]). The pertussis toxin is detoxified either by treatment with a chemical or by using molecular genetic techniques. Acellular pertussis vaccines contain substantially less endotoxin than whole-cell pertussis vaccines. Hence they provide similar protection but less frequent side effects and adverse events compared to whole cell pertussis vaccines.

Inactivated poliovirus vaccine (IPV) was available for use for a long time and was used in many developed countries. It is now used in South Africa in the form of a pentavalent



combination as the main vaccine to immunize children against polio. This vaccine has no risk of vaccine associated paralytic poliomyelitis, a very rare condition that has been associated with use of the live oral poliovirus vaccine (OPV).

DTaP-IPV//Hib vaccine (Pentaxim) is presented as a suspension for injection, in pre-filled syringe containing, diphtheria, tetanus, acellular pertussis, inactivated poliomyelitis vaccine, adsorbed, and with freeze-dried powder conjugate *Haemophilus influenza* type b vaccine.

**Schedule:** in the EPI-SA schedule there are three primary doses in the first year given at the ages of 6, 10 and 14 weeks and a booster dose at 18 months. The oral polio vaccine is now limited to 2 doses (birth and 6 weeks) as the inactivated polio vaccine (IPV) included in DTaP-IPV//Hib vaccine replaces the other doses. DTP-Hib is also replaced by DTaP-HBV//Hib vaccine.

**Contraindications:**

- Known hypersensitivity to any component of the vaccine or to pertussis vaccines (acellular or whole cell pertussis) or a life-threatening reaction after previous administration of the vaccine or a vaccine containing the same substance.
- Evolving encephalopathy.
- Encephalopathy within 7 days of administration of a previous dose of any vaccine containing pertussis antigens (whole cell or acellular pertussis vaccines)

Although not an absolute contraindication, vaccination should be postponed in the case of fever or acute illness.

**Administration:** the vaccine must be administered intramuscularly. The recommended injection sites are the antero-lateral aspect of the upper left thigh in infants and toddlers and the deltoid muscle in older children.

PENTAXIM must be injected immediately after reconstitution.

**Side effects:** the common side effects reported in 10-15% include irritability and local reactions at the injection site such as redness and induration.

## MODULE 4: SCHEDULE AND STRATEGIES FOR IMMUNISATION PRACTICES

---

The Expanded Programme on Immunisation (EPI) of the World Health Organization (WHO) is a global programme implemented in most countries of the world. It has been adopted by the Department of Health and is called EPI-SA.

### ROUTINE IMMUNISATION SCHEDULE

It is important for a child to receive immunisation before exposure to a disease, but after the level of antibodies the child received from the mother is sufficiently low, as this interferes with the effect of vaccines. Immunisation at an early age has been shown to be effective. Giving vaccines early in life reduces the risk of succumbing to the disease when the risk of dying from the disease is greatest.

Premature infants should be vaccinated in the same way as full term infants: same dose at the same age (e.g. 6 weeks dose when a premature infant is 6 weeks old from birth date).

**Table 4.1 Schedule for Childhood Immunisation - EPI-SA**

Age	Vaccine
Birth	TOPV (0), BCG
6 weeks	TOPV (1), RV (1), DTaP-IPV//Hib (1), Hep. B (1), PCV <sub>13</sub> (1)
10 weeks	DTaP-IPV//Hib (2), Hep. B (2)
14 weeks	RV (2), DTaP-IPV//Hib (3), Hep. B (3), PCV <sub>13</sub> (2)
9 months	MEASLES (1), PCV <sub>13</sub> (3)
18 months	DTaP-IPV//Hib (4), MEASLES (2)
6 years (school entry)	Td
12 years (school leaving)	Td*

- Do not administer any dose of Rotavirus to a child that is **more than 24 weeks**.
- Rotavirus Vaccine first dose can be given to children older than 12 weeks but younger than 20 weeks.
- Do not give OPV from 10 weeks of age, (OPV is given at birth & six weeks only).

TOPV	Trivalent Oral Polio Vaccine
RV	Rotavirus Vaccine
DTaP-IPV//Hib	Diphtheria, Tetanus, acellular Pertussis, Inactivated Polio Vaccine, Haemophilus influenzae type b
Hep. B	Hepatitis B Vaccine
BCG	Bacillus Calmette Guerin (Anti-tuberculosis Vaccine)
PCV	Pneumococcal Conjugated Vaccine
Td	Tetanus & reduced strength Diphtheria Vaccine

**Table 4.2 Route, Dose and Recommended site of Administration of Vaccine**

VACCINE	Form or presentation	DOSE	PREFERRED ROUTE	RECOMMENDED SITE	AGE
BCG	Powder	0,05ml	Intradermal	Right upper arm, at the deltoid muscle	Birth
TOPV	Liquid	Two drops	Oral	Oral	Birth & 6 weeks
RV	Liquid	1.5 ml	Oral	Oral	6 & 14 weeks
Hep. B	Liquid	0,5ml	Intramuscular	Lateral aspect of the right thigh in infants <i>under one year</i>	6, 10 & 14 weeks
DTaP-IPV//Hib	Liquid and Powder	0,5ml	Intramuscular	Lateral aspect of the left thigh in infants <i>under one year</i>	6, 10 & 14 weeks 18 months
Measles	Powder	0,5ml	Intramuscular	Lateral aspect of the left thigh	9 & 18 months
PCV	Liquid	0,5 ml	Intramuscular	Lateral aspect of the right thigh	6 & 14 weeks 9 months
Td	Liquid	0,5ml	Intramuscular	Left arm,	5-7 years (school entry) 12 and older (school leaving)

### Special Note

- For *BCG*, the recommended site is the *right upper arm at the insertion of the deltoid*.
- For *DTaP-IPV//HiB*, *Measles* and *Hep. B* the recommended site is the *lateral aspect of the thigh in infants under one year*. The *deltoid is preferred in children over one year*.

Use a 25-30 mm long needle (23 gauge) for deep intra-muscular (IM) injection.

Record on the Road-to-Health Booklet the vaccine given and the site at which it was injected, eg. [R] Thigh or [L] thigh or [R] arm.

**Table 4.3 Summary of the routine Immunisation schedule by vaccine and age**

Age ▶ Vaccine ▼	Birth	6 weeks	10 weeks	14 weeks	9 months	18 months	6 years	12 years
BCG								
TOPV								
RV								
DTaP-IPV//Hib								
Hep B								
PCV								

**Use every contact, which you have with a child to check the immunisation status.**

### VACCINATION OF PREGNANT WOMEN

South Africa has eliminated Neonatal Tetanus (NNT); however South Africa needs to have a program in place, which will ensure that the elimination status is maintained. Failure to maintain the elimination status can result in an increase in NNT cases and loss of the Elimination status. To ensure maintenance of NNT elimination the TT policy was revised as follows. Pregnant women can be given TT or Td.

**Table 4.4** TT or Td Immunisation Schedule for Pregnant Women

	TT or Td	TT or Td	TT or Td	TT or Td	TT or Td
Pregnant women with no previous immunisation (or unreliable immunisation information)	As early as possible in first pregnancy	At least 4 weeks later	At least 6 months later, or in next pregnancy	At least 1 year later, or in next pregnancy	At least 1 year later, or in next pregnancy
Pregnant women with 3 childhood DTP or DTaP doses	As early as possible in first pregnancy	At least 4 weeks later	At least 1 year later		
Pregnant women with 4 childhood DTP or DTaP doses	As early as possible in first pregnancy.	At least 1 year later			

- TT can safely be given in the first, second and third trimester of pregnancy;
- 5 adequately spaced doses of TT provide lifelong protection against tetanus.

**We need to:**

- Vaccinate all pregnant women with adequately spaced doses of TT or Td
- Strengthen our surveillance for neonatal tetanus in every district of the country,
- Educate the communities on clean plus safe delivery and cord care practices.

*You have an important role to play!*

- In the first pregnancy, if the woman comes for her second dose of TT less than 2 weeks before the expected delivery, give the second dose but remember that the baby is not fully protected against neonatal tetanus. Extra effort must be made to ensure a hygienic delivery and cord care.
- The mother's TT or Td vaccination status should be checked and outstanding TT or Td doses given when she brings the infant for check-up after delivery.
- If a case of neonatal tetanus is detected, check the mother's immunisation status, give the eligible TT / Td doses and provide a client-retained women's health card.
- Report every case of suspected or confirmed neonatal tetanus to your district EPI or CDC coordinator.

## SPECIAL IMMUNISATION SITUATIONS AND HIV INFECTED CHILDREN

### Immunisation of HIV-Infected Children

**Table 4.5: Recommended vaccination for HIV infected children**

Vaccine	Asymptomatic HIV infection	Symptomatic HIV infection
BCG	Vaccinate	<b>Do not vaccinate</b>
DTP/Hib or DTaP-IPV//Hib	Vaccinate	Vaccinate
OPV	Vaccinate	<b>Do not vaccinate</b>
PCV	Vaccinate	Vaccinate
Rotarix (RV)	Vaccinate	<b>Do not vaccinate</b>
Hepatitis B	Vaccinate	Vaccinate
Measles	Vaccinate	<b>Do not vaccinate</b>
Td	Vaccinate	Vaccinate
Tetanus toxoid	Vaccinate	Vaccinate

**NB! HIV positive children should receive a dose of measles vaccine at 6 months, which does not replace the 9 month dose. When they turn 9 months the measles vaccine should again be given, followed by the normal booster dose at 18 months.**

#### **Concurrent administration of all vaccines with Anti-Retroviral drugs**

- There are no drug interactions between anti-retroviral drugs and EPI vaccines.
- Children who are well controlled on ARV therapy can be vaccinated at the discretion of attending physician.

#### **Immunisation of Other Cases**

**Preterm babies:** Babies who are born before they are due should receive their immunisation doses in the same way as babies born at term. Therefore when a preterm baby turns 6 weeks, this baby will receive all 6 weeks doses; and it is likewise with subsequent doses.

**Trauma:** Give a booster dose of Tetanus Toxoid (TT) or Td dose after each trauma episode (unless there is proof that it was given in the preceding 5 years).

**Hepatitis B Vaccine:** For all personnel working in health care facilities (including cleaning staff and porters) 3 doses of 1 ml should be administered: 1<sup>st</sup> dose immediately (or when they start work), 2nd dose 1 month later and a 3<sup>rd</sup> dose 6 months after the first dose.

**Infants Born to Mothers who are on TB Treatment**

Infants who are born to mothers who are on anti –TB treatment should not be given BCG, they should be put on TB prophylaxis and followed up for BCG later. This includes mothers who have extensive resistant and multi-drug resistant (XDR & MDR) Tuberculosis.

## CATCH UP: FOR CHILDREN WHO MISSED SCHEDULED DOSES

### Pneumococcal Conjugate Vaccine (PCV) - Prevenar®

- If a child presents to a health facility before he/she turns 6 months and has not been vaccinated with PCV, give 2 doses of PCV, 4 weeks apart and a third dose at 9 months.
- If a child presents between 6 months and 9 months of age and has not been vaccinated with PCV when he/she presents to a health facility, give the first (1<sup>st</sup>) dose of PCV, give the 2<sup>nd</sup> of PCV dose 4 weeks later. After the 2<sup>nd</sup> dose of PCV the child comes back 8 weeks later for the third dose of PCV. The 9 months measles vaccine can be given with any of the 2 PCV doses (PCV 2 & 3). Ensure a minimum interval of 4 weeks between the first and second doses and 8 weeks minimum interval between the second and third doses.
- If a child presents for measles vaccine at 9 months and has not been vaccinated with PCV, give the first (1<sup>st</sup>) dose of PCV with measles vaccine, the child should come back 4 weeks later for the second (2<sup>nd</sup>) dose. The 3<sup>rd</sup> dose should be given after they have turned 1 year, it can be given together with Vitamin A. Ensure a minimum interval of 8 weeks between the 2<sup>nd</sup> and 3<sup>rd</sup> dose.
- Children who are older than 1 year but below 2 years, who have not been vaccinated with PCV when they present to a health facility (like children who present at 18 months who have never had a PCV dose) should be given 1 dose of PCV.
- Children above 2 years but below 6 years who have never been vaccinated with PCV and have no underlying medical condition can be given 1 dose of PCV.
- Children who are high risk with underlying medical conditions should be given 1<sup>st</sup> dose when they present, 2<sup>nd</sup> dose 4 weeks later and a 3<sup>rd</sup> dose 8 weeks after the second dose.
- **Remember to keep a minimum interval of 4 weeks between the 1<sup>st</sup> and 2<sup>nd</sup> dose of PCV.**
- **Remember to keep a minimum interval of 8 weeks between the 2<sup>nd</sup> and 3<sup>rd</sup> dose of PCV.**



### **Rotavirus Vaccine (RV) (ROTARIX®) Catch Up**

- If a child missed the 1<sup>st</sup> dose of RV (Rotarix®) at 6 weeks of age and is younger than 20 weeks, give the 1<sup>st</sup> dose of Rotavirus and the 2<sup>nd</sup> dose 4 weeks later.
- If a child missed the 1<sup>st</sup> dose at 6 weeks and is older than 20 weeks and younger than 24 weeks of age, give one dose of Rotavirus vaccine.
- Rotavirus vaccine should not be given to any child older than 24 weeks.
- Keep a minimum interval of 4 weeks between the 2 doses of RV.

### **DTaP-IPV//Hib (Pentaxim®)**

- Give all missed doses with the minimum interval of four **weeks**.
- Children who missed DTaP-IPV//Hib doses at 6, 10 or 14 weeks should receive all DTaP-IPV//Hib catch up doses. The first dose on first contact, 2<sup>nd</sup> dose 4 weeks later and 3<sup>rd</sup> dose 8 weeks after the 2<sup>nd</sup> dose.
- Children who missed DTaP-IPV//Hib doses at eighteen months should receive DTaP-IPV//Hib before the age of 24 months.
- Children above 24 months (2 years) and below 6 years who did not receive DTaP-IPV//Hib and other vaccines should receive: 3 doses of DTaP-IPV//Hib and Hep. B, with a minimal interval of 4 weeks and DTaP-IPV//Hib booster dose after 12 months; a first (1<sup>st</sup>) measles dose and a repeat measles dose 4 weeks later. These vaccines can be administered at the same time.

### **Hepatitis B Vaccine (HBV)**

- Give all missed doses in children below five years with the minimum interval of four weeks.

### **Measles Vaccine**

- All children **below seventeen (17) months**, who have missed the 9 months measles dose, should receive their first measles vaccine dose and receive the second dose at eighteen months or soon after. Ensure a minimal interval of 4 weeks between doses.
- All children **from seventeen months** and above, who have missed first dose measles vaccine should receive the first measles vaccine dose and receive the second dose after **four weeks**.

### **Tetanus reduced amount of diphtheria Vaccine/ Td (Diftavax®)**

- Give Td from six years of age.

### **Concurrent administration of BCG and Measles vaccines in missed opportunities**

- In missed opportunities, BCG and Measles can be given on the same day BUT use separate sites.
- BCG vaccine should not be given to *children older than one year*.
- To minimise missed opportunities, Road to Health cards should be checked by both public and private hospitals and clinics. If the Road to Health card is not up to date follow the table below as a guide to complete the Immunisation schedule.

***All EPI vaccines can be safely given at the same time, but always in different sites.***

If a child has missed the scheduled doses for age, he/she should be vaccinated with all missed doses as appropriate for age. The doses given for the first time should be recorded as first doses, regardless of the age. The child should be given the next booster doses after the recommended interval between the doses; refer table below.

**Table 4.6: Catch Up Vaccination Guide**  
(For Children Who Missed the Scheduled Vaccines)

Vaccine	Minimum age 1 <sup>st</sup> dose	Check the age at presentation, give the first dose and follow dose interval if another dose is indicated	Minimum interval between doses		
			Dose 1 to dose 2	Dose 2 to dose 3	Dose 3 to dose 4
BCG	Birth	<1 year Do not give after the age of 1 year	-	-	-
Hepatitis B	6 weeks	Up to 5 years	4 weeks	4 weeks	-
TOPV	Birth	<6 weeks	4 weeks (Use DTaP-IPV//Hib after 6 weeks)	-	-
		>2 years	4 weeks	4 weeks	4 weeks
DTaP-HBV//Hib	6 weeks	< 2 years	4 weeks	4 weeks	At 18 months of age.
		2 years to 6 years	4 weeks	4 weeks	After 12 months
Rotavirus (Rotatrix)	6 weeks	<20 weeks	4 weeks		
		20-24 weeks Give only one final dose. Do not give vaccine after the age of 24 weeks	-		-
Pneumococcal (PCV13)	6 weeks	<6 months	4 weeks	Give 3 <sup>rd</sup> dose at the age of 9 months	-
		6-9 months	4 weeks	8 weeks (final dose)	-
		>9 – 12 months	4 weeks (Final dose)	Give 3 <sup>rd</sup> dose when child is > 1year. Keep 8 weeks interval	-
		12-24 months	Give only one dose at presentation. No further doses required.	-	-
Measles	9 months	17 months or younger	At 18 months age.	-	-
		>17 months	4 weeks	-	-
Td	6 years	>6 years	Second dose at age 12 years	-	-

## MODULE 5: PREPARING FOR AN IMMUNISATION SESSION

---

It is the policy of EPI-SA that as far as possible “**Everyday is an Immunisation Day**”. Where and when this is not possible, and specific immunisation days are still used, these should be scheduled such that people can use them. *No client should ever be turned away because he/she did not attend on the scheduled immunisation day.*

### Immunisation Sessions in a Fixed Clinic

The arrangement of space in your clinic will affect how you work and how quickly clients are attended to. The space for immunisation should be:

- In a clean area not directly exposed to sunlight, rain or dust.
- Convenient for the health worker who is preparing and administering vaccines.
- Easily accessible to clients, but arranged such that they are not crowding around the immunisation station.
- Quiet enough for the health worker to be able to explain what he/she is doing.
- As far as possible provide some privacy.

The clinic should have:

- A space where clients can sit before being vaccinated.
- A space for registration, screening, vaccinating and recording.
- A table for vaccines and injection equipment.
- A chair on which a parent can sit while holding a child for immunisation.
- A chair for the health worker.

### Supplies and equipment needed

Generally the same supplies and equipment are needed for fixed and outreach sessions.

For fixed sessions you will need the following:

**Vaccine carrier and cooler box** with ice packs, to hold the vaccines and diluents during the session and keep them cold. The ice packs must be “conditioned” (remove frozen ice-packs from the freezing compartment before the session begins and allow the ice-packs to sit at room temperature until the ice begins to melt and water starts to form inside. You

should check if an ice-pack has been conditioned by shaking it and listening for water inside). Gel packs (made of the jelly like substance) **should not be used**.

## **Vaccines**

Take out from the fridge the number of doses of vaccines you think you will need for the entire session. You need to limit the number of times the fridge door is opened. The fridge should preferably be opened only twice a day. Once at the beginning of the session and at the end, to return remaining doses according to the opened multi-dose vial policy.

Select and use vaccines in the following order;

- First: Vials of OPV, TT, Td and Hepatitis B vaccine that were opened in the previous fixed session,
- Second: Unopened vials that have been out of the refrigerator for more than 3 hours
- Third: Other needed vaccines like DTaP/IPV-Hib, PCV, RV

## **Injection equipment**

Syringes and needles, use one sterile needle and one sterile syringe for each injection

Cotton swabs and clean water to clean the injection site

Metal file to open ampoules

## **Disposal of sharps**

A safety box for disposal of used syringes and needles

## **Emergency Kit:**

Adrenalin Injection (1:1000) solution – 2 ampoules

Hydrocortisone injection (100 mg)-1 vial

Disposable syringe having 0.01 ml graduations and 26G IM needle – 2 sets

Disposable syringe 5 ml and 24/26G IM needle – 2 sets

Scalp vein set- 2 sets

IV fluids, (Ringer- Lactate solution or normal saline) with drip set

AEFI reporting form

## **Record keeping material**

Immunisation Tally Sheets (if applicable)

Primary Health Care – Record Book

Patient register

Road to Health Cards

Paper, pencils and pens

## **Cleaning equipment**

Hand washing items

Container for rubbish

## **Preparing the vaccines and giving immunisation**

The vaccinator has two primary responsibilities:

- To administer potent vaccines at the correct time and in an aseptic manner.
- To correctly record the vaccines given on the Road to Health Card and on clinic held records, like the Primary Health Care Register.
- To help ensure that the child completes the immunisation series.

The vaccinator must maintain a *good relationship with the parents and care-givers at all times*. The parent or care-giver should know which vaccine the child received and why, what side effects are common and what to do if they occur. It should be made clear when the child should be returned for immunisation and why further doses are needed.

## **Aseptic vaccination practice**

*Always wash your hands* before touching sterile syringes and only touch the safe parts.

## **Giving injectable vaccines**

The skin should be adequately cleaned with cotton wool and water, (add soap if obviously dirty) before vaccinating. Alcohol and spirits should not be used, as these **destroy** some vaccine.

Assemble the syringe and the needle only when a client is waiting to be vaccinated.

Use a clean metal file to open the metal cap on ampoules and not a finger nail.

Disposable needles and syringes must be used only once.

**Use the same sterile needle and syringe to withdraw the vaccine and give the injection.**

## **Reconstitution of vaccine**

BCG, measles and DPT-IPV//Hib vaccines must be reconstituted before they can be used. Reconstitution means mixing the dry powder from a vaccine with a fluid called a diluent, so that the vaccine can be injected.

Use a 5 mL syringe and a size 18 gauge needle for reconstitution of vaccines.

Do not begin this process until clients have arrived and you are ready to vaccinate. Wash your hands with soap and water before reconstituting vaccines.

The vial/ampoule of the diluent to be sure that; (1) it is the diluent intended for the vaccine you are reconstituting and (2) the expiry date has not passed. Inspect the ampoule for cracks.

### **To open the ampoule proceeds as follows:**

- Hold it between your thumb and middle finger
- Use your index finger to support the top
- Take the metal file that is packed with the ampoules and scratch hard on around the neck of the ampoule.
- Wash the outside of the ampoule with cotton wool. This removes pieces of glass that might have been produced by filing and prevents them from getting into the vaccine.
- Break open the top of the ampoule.
- Draw the diluent into the syringe.

### **Opening the vaccine vial or ampoule**

Some vaccines come in vials. A vial is a glass bottle with a rubber stopper held in place by a metal cap. The centre of the metal cap is pre-cut so that it can easily be removed.

- Before opening a vial, read the expiry date on the label to make sure that it has not expired.
- Flick the vial.
- Lift the centre of a metal cap and bend it back to open, using the same metal file as for opening the ampoule.

Reconstitute by inserting the diluent into the vial. The diluent and the vaccine will now be mixed. Draw the mixture back into the syringe and inject slowly back into the ampoule. Repeat this step several times.

**Always label the vaccine vial with the date and time of reconstitution.**

The empty ampoule, the syringe and needle used in reconstitution can now be disposed of safely in the sharp disposal container.

Put the reconstituted vaccine immediately into the cooler box with ice packs.

### **Fluid vaccines**

These vaccines come in a fluid form and therefore do not need reconstitution.

PCV, Hep. B, Td, and TT should be shaken before drawing up each dose so that the vaccine is thoroughly mixed;

Clean the rubber stopper of the vial with clean water, before each withdrawal from the vial.

**Never prefill syringes with vaccines for use later**  
**Never leave the needle and syringe in a vial**

A significant number of vaccines are now single dose and come in liquid formulation. Check the expiry date of each vaccine, including the single dose vials before administering.

### **Giving an injectable vaccine**

#### **How to give a BCG vaccine – Intradermal BCG injection:**

- Position the child comfortably.
- BCG is injected on the upper right arm at the insertion of the deltoid muscle.
- Free the child's arm of clothing, and let the caregiver hold the child firmly.
- The dose of BCG vaccine is only 0,05ml. Use the special BCG syringe (0,1ml syringe). The BCG syringe comes pre-packed with the needle.
- Tilt the vial **slowly** to mix the constituted vaccine.
- Hold the child's arm with your left hand so that:
  - Your left hand is under the arm.
  - Your thumb and fingers reach around the arm and **stretch the skin tight**.
- Hold the syringe in your right hand, with the bevel of the needle facing up.
- Lay the syringe and the needle almost flat along the child's arm.
- Insert the tip of the needle just under the skin; push a little bit further keeping the needle flat along the arm, so that it goes into the top layer of the skin.
- Inject the contents and remove the needle.



**Figure 2. Giving an intradermal injection**

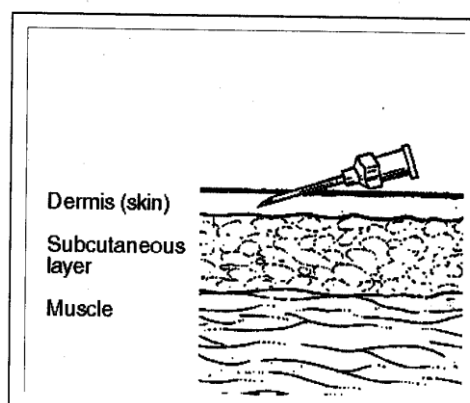

**Do not push too far and do not point down, as the needle will go under the skin**

If you have injected BCG correctly into the skin, you will see a clear, flat-topped swelling on the skin like a **mosquito bite**. The swollen skin may look pale with small pits. When an intradermal injection is given correctly the plunger is a bit hard to push.

If the vaccine goes in quite easily you may be injecting too deep. In this event proceed as follows:

- Stop injecting immediately. Correct the position of the needle.
- Give the remainder of the dose but no more.
- If the whole dose has already gone in under the skin, count the child as being injected. Do **not repeat** the dose.
- Ask the parent to return with the child if any side effects such as abscesses or enlarged glands appear.

### **Intramuscular injections**

Use a 2mL syringe and size 22-25 gauge needle for administering vaccines that are not prefilled.

**How to give intramuscular vaccines** (PCV, Measles, Hep. B, DTaP-IPV//Hib, Td and TT)

The intramuscular injections should be given on the thigh in children below 1 year and on the upper arm, deltoid muscle in children above a year.

**Never use the buttock as an immunisation site for women and children, because there is a risk of injury to the sciatic nerve, which can cause paralysis.**

### For thigh injections:

- Put your finger and thumb on the outer (anterior-lateral) aspect of the middle of the child's thigh.
- Pick up the muscle between your finger and thumb.
- Quickly at right angles push the needle straight into the skin between your fingers. Push the needle into the muscle below the subcutaneous tissue, and give the vaccine. Do not push the needle too far in.
- Withdraw the plunger and press with cotton wool.

**Figure 3. Giving an intramuscular injection (in the thigh)**

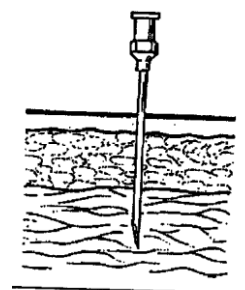

### For injections into the upper arm:

- Hold the child's upper arm, at the deltoid muscle, with the thumb on one side (inner) and the rest of the fingers on the other side.
- Pick up the muscle between your thumb and the index finger.
- Inject the vaccine into the muscle. The needle should go in at a sloping 45° angle, not vertically down.
- Do not push the needle too far in.

**Figure 4. Giving an intramuscular injection (deltoid)**



**How to give oral Polio Vaccine:**

- Oral polio vaccine comes in a plastic dropper or a glass vial with a plastic dropper to be attached.
- The Vaccine Vial Monitor (VVM) (refer to Opened Multidose vial policy, see module 6) is attached to each dropper.
- Check the VVM before use.
- The parent should hold the child firmly, with the head tilted back.
- Open the child's mouth by squeezing the cheeks gently between your fingers. This makes the child's lips point outwards.
- Hold the dropper over the child's mouth. Let two drops of vaccine into the child's mouth.

Repeat dose if child spits.

**How to give Oral Rotavirus Vaccine**

This vaccine is for **oral administration only**.

- The child should be seated in a reclining position.
- Administer into the child's mouth towards the inner cheek
- Squeeze the entire content of the tube by pressing the tube several times. A residual drop may remain in the tip of the tube.

## Recording and the Tallying of Given Doses

Immediately after vaccination:

- Record each dose given on the Primary Health Care Register and tally, indicating the vaccine dose given and the relevant dose no. For example record PCV 1 not just PCV.
- Children who come for the 9 months dose, once the measles and PCV3 dose have been given, tick as fully immunised in the Register if the child has received all vaccines doses scheduled from birth to 9 months, as long as the child is below 1 year.
- Record on the Road to Health Booklet: the given doses, the batch no, the date given as well as the return date. Sign in the appropriate space provided for each vaccine.
- Inform and show the mother/caregiver on the Road To Health Booklet: the vaccines given and the disease they protect against and the return date. Also tell her what to do in case of an adverse event.

### “Immunise a Child and Prove it”

By following the steps above you have properly vaccinated a child and you can prove it.

### Important to remember:

- Always give oral polio and rotavirus vaccines first.
- Complete the Road to Health Card (RTHC).
- Enter your initials and surname in the appropriate column on the RTHC, next to vaccine given.
- Complete the tally sheet, register and other appropriate health information tools.

### When Conducting an Immunisation Session in a clinic

Always:

- Carry and store only the quantity of vaccines needed for the session from the fridge to the vaccination point in a cold box/vaccine carrier for each vaccinating room.
- Do not hold a vial in the hand for too long.
- While administering, measles and oral polio vaccine can be stored directly on the ice-packs, but DTaP-IPV//Hib, Td, TT, Hep. B and Rotarix should not be put directly on the ice-packs.
- Reconstituted measles and BCG vaccines *must* be protected from light, so the cold box must be kept closed.

## **Contra-indications to Immunisation**

*There are very few contra-indications to giving the EPI vaccines. Do not vaccinate a sick child if the mother seriously objects, but encourage her to bring the child for immunisation on recovery.*

### **General Contra-indication**

- Children who have a known severe hypersensitivity to any component of the vaccine, or who have had a serious allergic reaction to a previous dose of a specific vaccine, should not receive such a vaccine.
- Postpone vaccination if the temperature is **38, 5°C** or above.

### **Specific Contra-indication**

#### **Oral Polio Vaccine (OPV)**

- Do not give Oral Polio vaccine to children who are sick with AIDS. Refer for medical opinion.

#### **Bacillus Calmette Guerin (BCG)**

- Do not give BCG to a child that is **more than 12 months old**.
- Do not give BCG vaccine to children who are sick with AIDS.
- HIV exposed newborns who are well enough to be discharged should be given BCG.
- HIV exposed newborns who are sick and have other complications should have PCR at six weeks, and BCG can be given if PCR results are negative.
- Do not give BCG to a newborn if the mother is on anti-TB drugs, this child should be on TB prophylaxis and be followed up for BCG later.

**BCG should still be given to HIV exposed children.**

#### **DTaP-IPV//Hib**

- Do not give DTaP-IPV//Hib to a child with epilepsy that is not controlled

#### **Pneumococcal Conjugate Vaccine (PCV) (Prevenar®)**

- Do not give PCV on the same site with DTaP-IPV//Hib but PCV can be given concurrently with any of these vaccines at different sites.

## **Measles Vaccine**

Do not give Measles vaccine to children who are have stage 3 or 4 clinical AIDS infection.

## **Rotavirus Vaccine (RV) (Rotarix®)**

- Do not give Rotavirus vaccine if a child has history of chronic gastro-intestinal disease or severe diarrhoea. Refer the child for medical opinion.
- Do NOT give Rotavirus vaccine if the child is  $\geq 24$  weeks.

## **Tetanus and reduced amount of diphtheria Vaccine (Td), Diftavax®**

- Do not administer Td for children who are below **6 years** of age.

If a child is well enough to be sent home, The child is well enough to go home immunised.

## **Organising outreach immunisation sessions**

Outreach immunisation sessions are held in a location other than a fixed health facility. They are held periodically at intervals of one week, fortnightly or one month. Generally outreach services are held in the same place, on the same day of the week and the same time. This is to maximise attendance.

## **Equipment and supplies needed**

The same supplies are needed as in the fixed clinic.

You will need a vehicle that is in a good working condition.

## **Setting up an outreach site**

The place where you give immunisation may be in a building or in the open. If in a building, it should be well lit and well ventilated. If in the open air it should be in the shade.

In arranging the immunisation site make sure that:

- The waiting area is clean, comfortable and out of the sun
- People are effectively guided to the entrance, the stations and the exit by means of signs or arrangements of chairs, tables, ropes and other items
- The number of people at the immunisation and other stations are limited, so there is no overcrowding
- Everything you need is within reach

Keep the carrier/cooler box in a shade. Keep the lid closed.

Keep vaccines not currently in use in the cooler box.

For instructions on how to pack a cooler box for outreach (vaccine shipment), refer to the cold chain manual, under distribution of supplies.

Involve the community leaders and other members of the community in setting up outreach services. Input of the community will be invaluable in running an efficient outreach service.

### **When Conducting an Immunisation Session at an outreach point**

- Aim to take a little more vaccine than you expect to use at the outreach point.
- Take a vaccine carrier (six pack size) in addition to the larger cold box, so that the opened vials of vaccines are separated from the unopened vials.
- Always attempt to keep the cold box in the shade, cover it with a wet cloth and do not leave it in a parked car for a long time.
- Open the cold box only when necessary. Close it quickly and keep the lid on tightly.
- If the lid comes off easily, secure it by taping it firmly during transportation.
- Always, keep a vaccine cold chain monitoring device in the centre of the cold box and check the temperature when opening. *Once the temperature reaches 5°C, it will rise to 8°C in a few hours, so you need a fridge or a replacement supply of ice-packs soon.*
- The opened, Td, TT and Hep. B vaccine vials should be placed back into the fridge on return *only if you are sure that the cold chain was maintained at all times.*
- Opened vials of OPV should only be used for 1 month, discard after 1 month (28 days) even if the VVM has not reached the discard stage.
- The VVMs on opened and unopened vials of OPV must be checked to see if the vaccine can still be used before transferring to the fridge.
- Vaccine vials that are returned to the fridge should be marked so that they are used first at the next immunisation session.

**Discard open vials of reconstituted measles and BCG after each Immunisation session or after six hours, whichever comes first.**

**NB!** Definition of a Fully Immunised Child below 1 year = a child at 9 months or between 9 months and 1 year who has received all scheduled vaccine doses, which are: BCG, OPV 0 & 1, DTap-IPV//Hib x3, Hep.B x3, Measles x1, RV x2 and PCV x3.

## MODULE 6: THE COLD CHAIN - THE KEY TO POTENT VACCINES

---

The cold chain refers to the system; of all the *people, equipment*, transport and procedures responsible for ensuring that vaccines reach the vaccinee (child or woman who receives a vaccine) having been maintained in the appropriate specified temperatures. Vaccines are heat sensitive, but some vaccines are also destroyed by freezing. The cold chain is therefore crucial in maintaining the potency of vaccines. Vaccines should be transported, stored and handled in the appropriate manner from the manufacturer till the point of the vaccinee.

For facilities to achieve and maintain the standard requirements for adequate cold chain management the following should be adhered to:

- Each facility must assign a person and a deputy who are responsible for the vaccine fridge. This person may be the Vaccinator and will: properly pack vaccines in the fridge, monitor fridge temperatures, defrost and clean the fridge as required, report malfunctioning and take action when there is power failure and when the fridge is not functioning.
- Only vaccines should be stored in the vaccine fridge.
- Every vaccine fridge should have a fridge tag or a thermometer in the fridge.
- Cooler boxes used during vaccination should have thermometer
- Fridge temperature should recorded twice daily.
- A vaccine fridge should not be overstocked.

### THE VACCINE FRIDGE - YOUR PARTNER IN IMMUNISATION

In your health facility, there are a number of ways of checking that the temperature in the vaccine fridge remains within the safe range (2-8°C):

- Most importantly there should be:
  - A working dial thermometer hanging vertically in the middle of each vaccine fridge, which is to be read and recorded twice daily by the person responsible for the fridge or her/his deputy. **OR**
  - **Fridge tag** is placed in the middle shelf of the fridge where Hep B, Td and other freeze sensitive vaccines are placed. (See Temp. Monitoring Tools)



- The temperatures should be recorded on the daily temperature chart (Appendix 4). If at any time, the temperature strays outside the safe temperature range; OR if the Fridge tag alarms, then immediate action is necessary. Check:
    - Is the power supply connected, is the gas cylinder empty?
    - Is the door closing properly, opened too often, left open?
    - Is the door seal intact?
    - Is the fridge overloaded?
    - Is there an ice build-up?
    - When last did you dust the gas coils behind the unit?
- Take corrective action and contact your supervisor if you need assistance.

### **Arranging Vaccines Correctly In Refrigerators**

Correct packing of vaccines and diluent in the refrigerator is vital if they are to be kept at safe temperatures and for vaccines to remain potent. Most refrigerators used for vaccine storage in South Africa are not designed for keeping vaccines. It is the objective of EPI-SA to replace equipment used for the storage of heat sensitive medical products with the equipment specifically designed for such storage.

The vaccines should be arranged in such a way as to facilitate air circulation and reading their identification as well as expiry date. Hence, vaccines whose expiry date is closest will be used first (***‘first to expire, first out’ [FEFO]*** principle). Vaccines whose use-by date has passed (expired) should not be preserved, but put aside for destruction as per Treasury instructions.

Unused vials brought back from an immunisation session should be marked and arranged separately. These must be used first in the next session.

Open the refrigerator only twice a day, and over above that only in case of necessity. Have a clear idea of what you want to take out before you open the refrigerator, and do so quickly in order not to leave the refrigerator open for too long.

Figure 5. A Clinic Fridge Showing Vaccines Stored Correctly

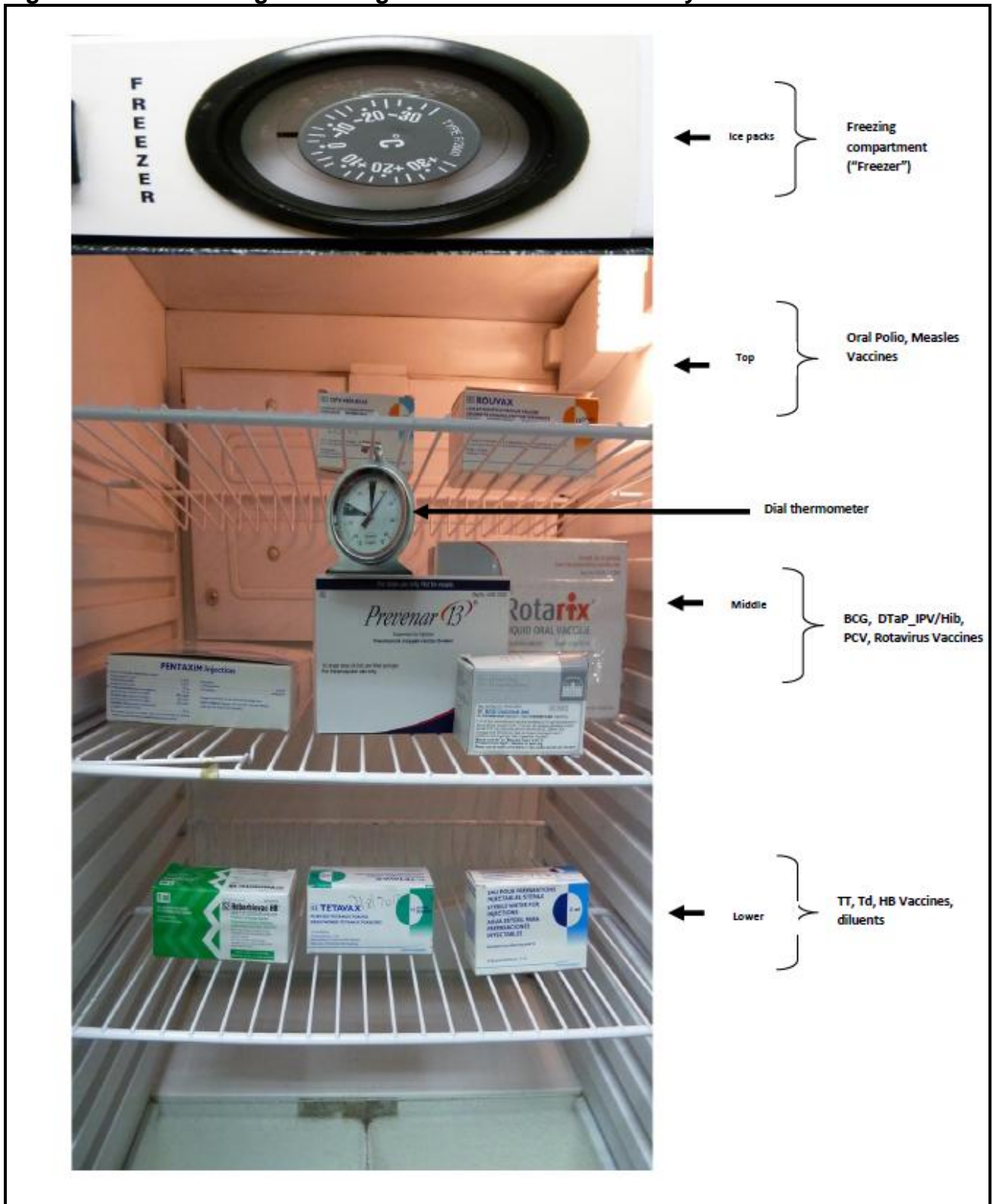

**Note:**

The freezing compartment should only be used to store ice packs.

- Vaccines should not be stored in the freezing compartment of the clinic fridge.
- Arrange ice-packs vertically.

Note! In domestic fridges with the freezer at the bottom, the top shelf is still the coldest part of the fridge and the bottom shelf close to the vegetable drawer is still the warmest part.

**The Vertical Fridge:**

- Store *OPV and Measles* and Yellow fever (private sector) vials in the top shelf.
- Store *BCG, DTP, DTaP-IPV//Hib, RV, PCV, Td, TT, Hep. B, Hib and diluent* on the middle shelves away from freezing plate. **IF FROZEN! DO a shake test when you suspect that a vaccine has been frozen.**
- Store bottles of water, *with salt added* to discourage drinking, on the bottom shelf, in the vegetable drawers and in the fridge door to help stabilise the temperature.
- Hang the thermometer from a shelf so that it is in the centre of the refrigerated area.
- Put the Fridge tag in the middle of the fridge.
- Never store vaccines in the fridge door.
- Do not store food in the vaccine fridge.
- If there is no fridge available for other medicines, ensure that these are stored completely separated from the vaccines and are clearly marked.

**Chest refrigerators:**

- The vaccines should always be arranged in the baskets provided.
- A row of ice packs should always be kept at the bottom of the refrigerator before being placed in the freezing compartment. These will help to prevent vaccines in the fridge from freezing and can also be used as 'cold packs'.
- OPV and measles vials will be packed in the lower section of the refrigerator compartment on top of the ice packs. BCG above these.
- The DTaP-IPV//Hib, Hep. B, TT, Td, RV and PCV vials will be arranged in the upper basket, so as to keep them away from the bottom where they may be exposed to negative temperatures. The diluents for BCG and Measles will also be packed near the DTaP-IPV//Hib and TT vials.

Overstocking of vaccines will place all vaccines at risk as it will limit air circulation making it difficult to achieve consistent, stable air condition throughout the refrigerator.

Ensure that the fridge is in a cool place, against an inside wall of the clinic and away from direct sunlight. Vaccine fridges should be kept locked where possible. *Electric fridges* must have their own plug sockets, which are clearly marked, to ensure that they are never unplugged by mistake. Ensure that there are no heaters near the fridge.

If you have a *solar powered fridge* make sure that the solar panel is kept clean and not shaded. Check the solar batteries regularly and maintain them in accordance with the manufacturer's instructions.

If you have either a *paraffin or gas fridge* it is important to check that there is sufficient fuel or gas at the beginning of each day and before weekends. Additional fuel or gas should be readily available.

## Defrosting

- Defrosting must be done if ice accumulates and is *more than half 2 centimetres thick*.
- Put vaccines and ice-packs in a cold box before turning off the fridge.
- Leave the door open and let the ice melt.
- Do not use sharp objects to scrape off the ice as these may damage the fridge.
- After wiping the fridge clean and dry, turn it on and wait until the *temperature is below 8° C* before replacing the vaccines.

## A vaccine friendly fridge

- **Fridge temperature should be between 2 and 8°C**
  - **No vaccines should be frozen at facility level**
  - **Do not keep food or drink in the vaccine fridge**
  - **Do not store vaccines in the door of the fridge**
  - **Always plan before opening the fridge**
  - **Aim to only open fridge door 2 or 3 times a day**
  - **Never keep expired vaccines in the fridge**
  - **Arrange vaccines to allow air to circulate between boxes**
  - **Ensure vaccines do not touch the evaporator plate at the back of the fridge**
  - **Record the temperature of the fridge twice daily**
- Do not overstock the fridge.**

If defrosting is necessary every week, the door of the fridge is probably not sealing properly. The seal needs adjustment or replacement, so contact your supervisor.

### **When your fridge fails**

*Always be prepared for fridge failures.* These might be due to:

- electrical failures,
- running out of paraffin or gas or
- mechanical problems.

You should:

- Identify another fridge beforehand, which can be made available during fridge failure.
- Obtain permission to use a fridge that will not be affected by the same power failure.
- Develop a good relationship with a local technician who has facilities to make minor emergency repairs.
- Always have a cold box and frozen ice-packs ready.

Ensure that there is a written contingency plan for fridge failure on a wall close to the fridge. A decision to respond must be made without delay, preferably within the first hour of a fridge failure. The fridge thermometer should be kept with the vaccines at all times. Do not discard vaccines before checking with your supervisor or vaccine coordinator.

### **Packing a cold box for transport of vaccines**

Use a cold box with rigid and adequately thick walls.

- Remember a cold box cannot make vaccines colder. It can only maintain the original temperature.
- Check that the cold box seal is intact and that there are no cracks in the cold box. If the box is broken, do not use but replace it.
- Ice-packs should be properly conditioned before use. Only water icepacks which rattle with a layer of water should be used for vaccines.
- You need sufficient frozen ice-packs to keep the vaccines cold for twice the time that you anticipate it will be stored in the cold box. Line the bottom, sides and top of the cold box with ice packs.
- Ensure that PCV, RV, DTaP-IPV//Hib, Td, TT, and Hep. B are not in direct contact with frozen ice packs. They can be protected from freezing by wrapping them in paper or cloth.

- Measles and Polio vaccines should be placed at the bottom of the box next to the ice. Next pack the BCG vaccines, above them place PCV, RV, DTaP-IPV//Hib, Td, TT, and Hep. B vaccines and diluents.
- Place a thermometer in the centre of the cold box.
- Close the lid tightly and keep it closed as much as possible.

### **The Shake Test**

The *Shake Test* will confirm whether a freeze sensitive vaccine like Hepatitis B, Td or TT that is suspected to have frozen was actually frozen. If these vaccines are frozen to a solid (obviously frozen); they should not be used. If a vaccine has never been frozen the liquid will be smooth and cloudy immediately after shaking and will have no sediment after standing for 5 minutes. If the vaccine has been frozen, granular particles might be seen after shaking and sediment will be visible after standing for 5 to 30 minutes. Sedimentation occurs faster in a vaccine vial that has been frozen than in a vaccine vial from the same manufacturer that has never been frozen.

**Note:** At facility level the test procedure described below should be repeated with each suspected vaccine vial. It is done when temperatures have dropped below 0°C and there is suspicion that freeze sensitive vaccines might have been frozen.

#### **Test procedure:**

##### **1. Prepare a frozen control sample:**

Take a vial of vaccine of the same type and batch number as the vaccine you want to test, and made by the same manufacturer. Freeze the vial at -20°C until the contents are solid, and then let it thaw. This vial is the control sample. Clearly mark the vial so that it cannot later be used by mistake.

##### **2. Choose a test sample:**

Take a vial from the batch that you suspect has been frozen. This is the test sample.

##### **3. Shake the control and test samples:**

Hold the control sample and the test sample together in one hand and shake vigorously for 10-15 seconds.

#### 4. Allow to rest:

Leave both vials to rest. Start to check in the first 5 minutes and may observe for up to 30 minutes.

#### Compare the vials:

View both vials against the light to compare the sedimentation rate. If the test sample shows a much slower sedimentation rate than the control sample, the test sample is probably potent and may be used. If the sedimentation rate is similar and the test sample contains flakes, the vial under test has probably been damaged by freezing and should not be used. Note that some vials have large labels which conceal the vial contents. In such cases, turn the sample and reference vials upside down and observe sedimentation taking place in the neck of the vial.

Figure 6.: Shake Test

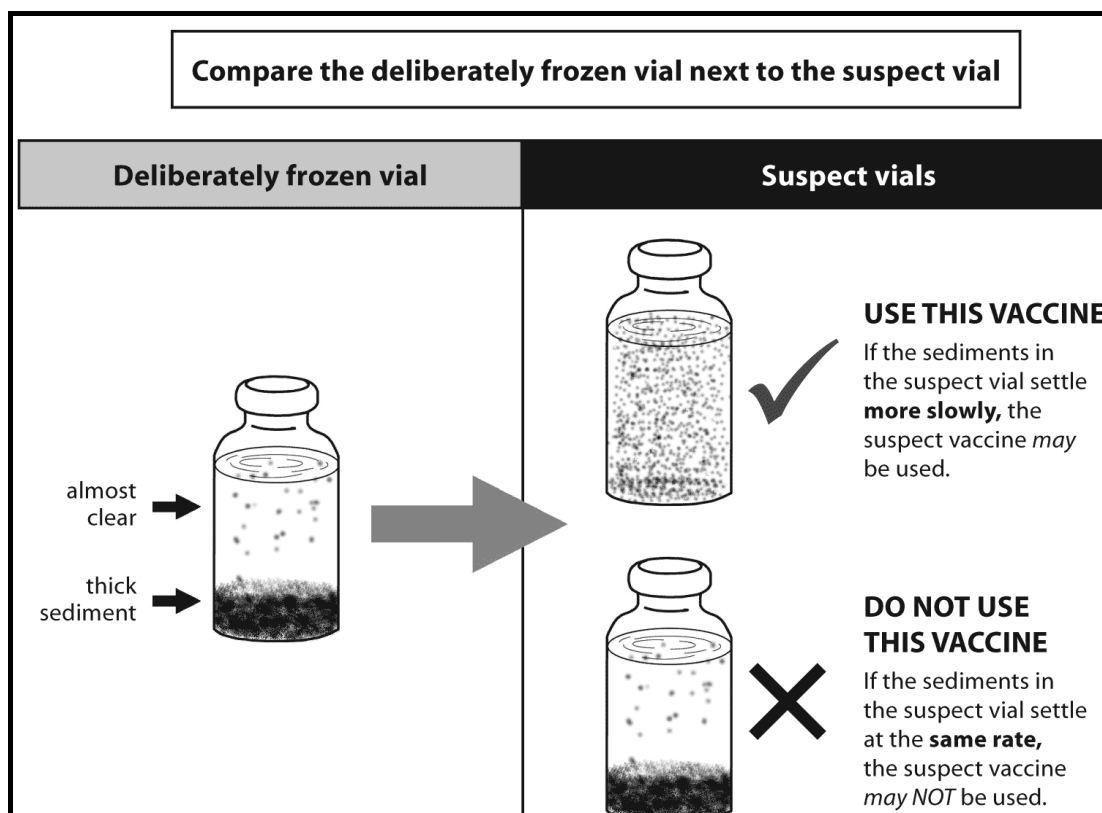

**Figure 7: Shake Test- Frozen and unfrozen vaccines, 5 to 8 mins after shaking**

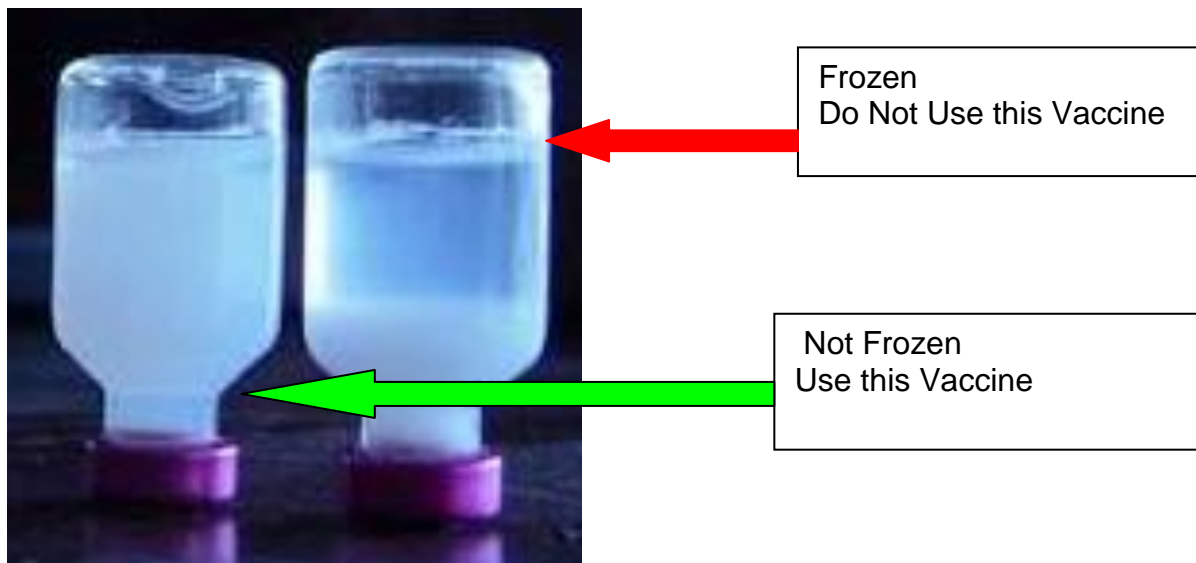

**Note: Of importance is the striking difference in the rate of sedimentation between the frozen and not frozen vaccine. The sedimentation is much faster with the frozen vaccine.**



## MODULE 7: THE TEMPERATURE MONITORING DEVICES

---

Vaccines are sensitive to extremes of temperature, thus the need to maintain cold chain for their storage and transportation. Some vaccines are more sensitive to heat than others. Of the commonly used EPI vaccines OPV, Measles, BCG are heat sensitive. Others like DTaP-IPV//Hib, Td, Hep. B, Rotavirus and Pneumococcal Conjugate vaccines are more sensitive to freezing. We therefore need temperature monitoring tools to monitor the temperatures vaccines are exposed to; so that should the temperature deviate outside the specified range, corrective measures can be taken. These devices help to maintain the optimal potency of vaccines.

The temperature monitoring devices discussed in this module only relate to the health facility level. Temperature monitoring tools that may be used at depots and during transportation are not covered this guideline. It is important that staff at facility level, programme managers at all levels and supervisors know how to read the different devices and interpret recordings properly.

It is emphasised that at facility level and at immunisation points all vaccines should be stored between 2 and 8 °C. No vaccines should be frozen.

Some of the temperature monitoring tools that are discussed in this module are not currently available in many facilities. However, these tools should soon be available as EPI-SA is in the process of standardizing cold chain equipment used in government Primary Health Care Facilities.

The temperature monitoring devices that should be used at facility level are the following:

- Temperature Monitoring Charts
- Dial Thermometers
- Vaccine Vial Monitor (VVM)
- Fridge Tag
- Freeze Tag

## THE TEMPERATURE MONITORING CHARTS

EPI-SA uses graph charts for temperature monitoring. These should be displayed in front of the vaccine fridge. The temperature charts record the reading of the thermometer in the fridge either a dial thermometer or a fridge tag. It is expected that all facilities will have fridge tags and freeze tags in the near future. Those facilities that currently do not have fridge tags, temperature readings of the dial thermometer should be used. Digital temperature readings outside the fridge should not be used.

The person responsible for the vaccine fridge should ensure that temperatures are checked and recorded on the temperature chart twice a day; in the morning when the vaccine fridge is opened to take out vaccines for the day's session and in the afternoon at the end of the vaccination session. Remember vaccine fridges should only be opened twice a day: in the morning and afternoon. Temperature charts should be kept for a minimum of 6 months. See Appendix 4 temperature charts

## FRIDGE TAGS

Fridge tags will replace dial thermometers in vaccine fridges of all government facilities. It monitors temperature vaccines are exposed to and provides 30 day history of storage temperatures. The temperatures for the last 30 days are read directly from the fridge tag

**Figure 8.: Fridge Tag**



## **Features of a Fridge tag**

- It provides an LCD display of temperature
- Stores up to 30 days temperature recordings that can be checked on history mode
- It does not need a computer or software. Readings cannot be down loaded.
- Has a pre-set alarm for temperatures above 8°C for more than 10 hours continuously and less than 0.5°C for more than 1 hour continuously.
- Displays highest and lowest temperatures reached compared to pre-set alarm as well as their duration.

It requires replacement after approximately 2 years (Low battery indicator).

## **How to Use the Fridge tag.**

Once the fridge tags are introduced, the dial thermometers should be removed to avoid confusion. The temperature monitoring charts currently in use will not be appropriate for the fridge tag. Fridge tag temperature monitoring charts are in Appendix 5, should be used.

For a step by step guide on the use of Fridge tag, refer to the User Manual supplied with the device. Refer to Appendix 6 for a copy of the User Manual.

Training will be conducted on the use of Fridge tags and the corresponding temperature monitoring charts.

## **THE VACCINE VIAL MONITOR (VVM)**

Vaccine Vial Monitors (VVMs) are heat sensitive chemicals applied to the vial label or cap. Vaccine Vial Monitors (VVMs) were invented to monitor cumulative heat exposure since leaving the factory. They were initially only available for oral polio vaccine, but are now found on oral polio, measles and BCG vaccines. It is planned that in the near future all vaccines will have VVMs

The VVM monitors each individual vial. It allows the vaccine in the vial to continue to be used safely as long as the VVM colour does not indicate damage from heat and the expiry date of the vaccine has not passed. VVMs therefore help to avoid discarding vaccine vials which may have been exposed to heat but which are still potent,

The VVM is a circle with a small square inside it. The VVM for a vaccine with preservative (can be used for subsequent sessions) is on the label, while the VVM for a vaccine without preservative (must be discarded after 6 hours) is on the cap (Measles, BCG, YF, ...)

The **inner square** of the VVM is made of heat-sensitive material that is light in colour initially and **becomes darker** when exposed to heat. **The inner square is never pure white in colour, but has a slight bluish tinge.** The inner square is initially much lighter in colour than the outer circle. It remains so until the temperature and/or the duration of heat reaches a level that is likely to degrade the vaccine beyond the acceptable limit.

The combined effects of time and temperature cause the inner square of the VVM to darken gradually and irreversibly. The rate of colour change increases as heat exposure increases. At the discard point the inner square is the same colour as the outer circle. This indicates that the vial has been exposed to an unacceptable level of heat and that the vaccine may have degraded beyond the acceptable limit. The inner square continues to darken as heat exposure continues, until it is much darker than the outer circle. If the inner square becomes as dark as or darker than the outer circle the vial must be discarded.

The VVM does not directly measure vaccine potency but it gives information about the main factor that affects potency, heat exposure over a period of time.

**Figure 9.: Reading a Vaccine Vial Monitor**

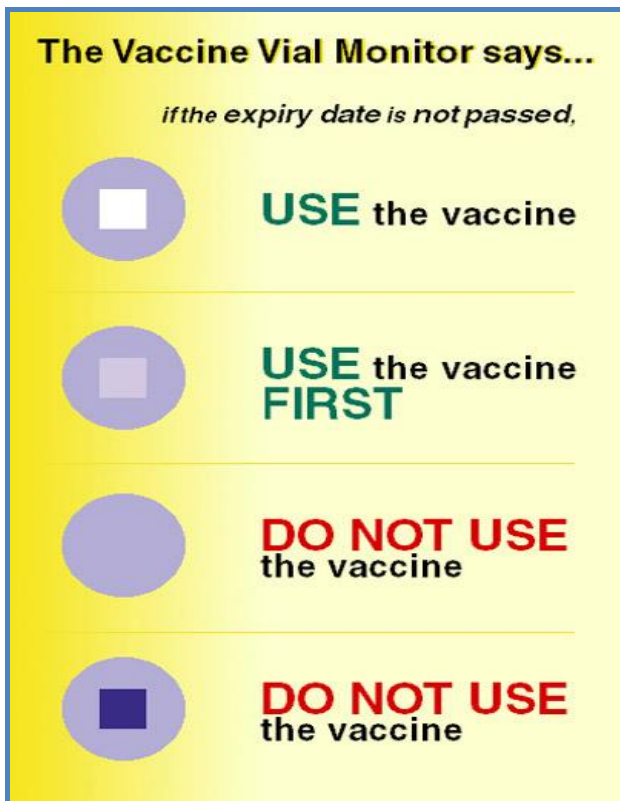

## THE FREEZE TAG

Freeze tag monitors freeze sensitive vaccines during storage. Can also be used during transport. It should be available in vaccine fridges of Primary Health Care facilities as part of standardized cold chain equipment. It should be placed inside the fridge in the shelf with freeze sensitive vaccines.

Main Features of a Freeze tag

- **Changes from “check” to “cross” when** Exposed below 0°C for more than 60 minutes period
- Replaces Freeze Watch™ glass/alcohol indicator
- Should not be stored below +4C
- Discard when indicator shows a cross.

**Figure 10.: Freeze tags**



Fridge temperatures have not dropped below 0°C for more than 60 mins.

Continue to use this freeze tag.

Can be used continuously or many times over its shelf life of 5 years.



Fridge temperatures have dropped below 0°C for more than 60 mins.

Investigate the cause of low temperatures.

Adjust the thermostat accordingly.

Conduct a Shake Test for freeze sensitive vaccines.

Freeze tags that remain with a check sign can be used continuously or many times over their shelf life (5 yrs).

## THE EPI-SA OPEN-MULTI-DOSE VIAL POLICY

As a result of continued advancement in technology, more stable vaccines are now being produced. Some of the vaccines remain potent for several days after opening the vial. These vaccines do not need to be discarded at the end of the immunisation session. In keeping with these developments, EPI-SA has revised its policy on opened multi-dose vials as follows:

1. The revised policy applies only to vaccines which:
  - ❑ meet WHO requirements for potency and temperature stability;
  - ❑ are packaged according to internationally recommended standards;
  - ❑ Contain an appropriate concentration of preservative (injectable vaccines only).
2. For such vaccines the revised policy states *that*:
  - 2.1 **Opened vials of TT, Td and Hepatitis B vaccines (including outreach)** may be used in subsequent immunisation sessions **for a maximum of one month**, provided that each of the following conditions have been met:
    - ❑ The expiry date has not passed; **and**
    - ❑ The vaccines are stored under appropriate cold chain conditions (2-8° Celsius).
    - ❑ The date the vial was first used is clearly marked on the vial
    - ❑ VVMs have not reached the discard point ( when VVMs are available)
  - 2.2 **Opened vials of OPV (including outreach) for a maximum of one month**, provided that:
    - ❑ The VVMs on opened vials of OPV have not reached the discard point (the VVM's inner square **must** be lighter than the outer circle); **and**
    - ❑ The expiry date has not passed.
3. **DTaP-IPV//Hib** must be used immediately after reconstitution of the freeze-dried suspension. It should not be used after 30 minutes of reconstitution.
4. Opened vials of measles, yellow fever and BCG vaccines must be discarded at the end of each session or at the end of 6 hours, whichever comes first.

5. An opened vial **must be discarded immediately** if any of the following conditions applies:
- sterile procedures have not been fully observed; **or**
  - there is even a suspicion that the opened vial has been contaminated; **or**
  - there is visible evidence of contamination, such as a change in appearance, floating particles, etc

If in doubt, contact your supervisor or Provincial EPI Manager.



## MODULE 8: IMMUNISATION AND INJECTION SAFETY

---

### BACKGROUND

#### ***“First Do No Harm”***

Health workers have a professional commitment to preserve life and promote health. Health workers swear under oath that they will do what they consider best for the benefit of their patients and abstain from whatever is deleterious and harmful. Patients, care givers and their children depend on health workers to make them healthy not sicker. The *“First Do No Harm”* principle is the basis of international efforts to achieve safe and appropriate injections.

The World Health Organization (WHO) estimates that unsafe injections accounted for: 32% of Hepatitis B, 40% of Hepatitis C, 28% of liver cancer, 24% of cirrhosis and 5% of HIV, all new infections in the year 2000. This has contributed to the realisation that unsafe injections carry a much higher disease burden than previously realised.

#### **Using safe injection technique and equipment**

Unsafe injections can spread pathogens more efficiently than breathing, swallowing or sex.

#### **Safe injection technique**

Humans survive in the environment full of germs because the skin is an excellent outer barrier, and the immune system is an excellent inner barrier. The body has many mechanisms that prevent pathogens from passing through the respiratory tract, the skin, reproductive organs, mouth or stomach. Injections carry pathogens directly into inner system - by passing these protective barriers.

The injections may introduce infections into the inner body through the following ways:

- Injections may transfer pathogens from fingers or objects to the needle.
- Needles pick up pathogens present on the skin.
- Injections may be of contaminated vaccines.
- Injections may be using unsterile equipment.

**REMEMBER: Use a sterile syringe and a sterile needle for each immunisation or DO NOT administer the vaccine.**

### **An injection is considered safe when it is safe for:**

- the *child (recipient)*, when a health worker uses a safe potent vaccine, a sterile syringe and a sterile needle and appropriate injection techniques;
- the *health worker*, when he or she avoids needle stick injuries; and
- the *community*, when waste created by used injection equipment is disposed of appropriately.

### **Practices that can harm the recipients:**

- Re-using a syringe or a needle.
- Changing the needle but re-using the syringe.
- Giving an injection when there are safer alternatives.
- Keeping freeze-dried vaccines (BCG & Measles) more than 6 hours after reconstitution.
- Attempting to sterilise and re-use disposable syringes.
- Pre-loading multiple syringes with doses and injecting multiple persons.
- Apply pressure to bleeding sites with used material or a finger.
- Vaccinating infants in the buttocks.
- Leaving a needle in the vial to withdraw additional doses.
- Storing medication and vaccine in the same refrigerator.
- Touching the metal part of the needle.

### **Practices that can harm health care workers**

- Recapping needles.
- Placing needles on any surface or carrying them a distance prior to disposal.
- Sharpening blunt or blocked needles.
- Cleaning or sorting used syringes and needles.

### **Practices that can harm the community**

- Leaving used syringes in areas where children can play with them.
- Giving or selling used syringes to vendors who will resell them.
- Leaving used needles in areas accessible to the community.

## TYPES OF INJECTION EQUIPMENT

The following equipment is used to administer injectable vaccines:

**Table 8.1 Injection Equipment**

Equipment	Remarks
Auto-Disable (AD) syringes – prevent reuse of syringes	specifically designed for EPI equipment of choice
Prefilled injection devices	available for some antigens only like Pentaxim and PCV
Retractable device (safety syringes) - prevent needle stick injuries	not specifically designed for EPI at time of printing this book
Single use disposable syringes and needles	for injecting and mixing purposes
Reusable syringes and needles	not recommended, not used in South Africa

### Disposable syringes and needles

Ordinary disposable single-use syringes and needles are still used in a number of facilities in South Africa.

Vaccines that must be reconstituted, such as measles vaccine, require a large syringe to mix the diluent with the vaccine. Ordinary disposable syringes and needles may be used to reconstitute these vaccines. Use one disposable syringe and one needle for each vial of vaccine to be reconstituted. After reconstitution the syringe and the needle should be discarded immediately. Use a 5mL syringe for reconstitution.

Ensure that you have a sufficient stock of syringes and needles to render the immunisation services (at the fixed and outreach sessions).

### Giving the right vaccine safely

A number of elements are crucial in ensuring immunisation injection safety, these include; safe injection equipment, the right vaccine, proper maintenance of the cold chain, proper reconstitution and safe administration of vaccines.

**Table 8.2 A summary of common incorrect practices and the adverse**

Practice	Possible severe reactions following immunisation
Non-sterile injection Reuse of disposable syringe or needle Improperly sterilised syringe or needle Contaminated vaccine or diluent or syringe	Infection such as local abscess at injection site, sepsis, toxic shock syndrome, or death Blood-borne infection transmitted such as Hepatitis B ,Hepatitis C and HIV
Reconstitution error Inadequate shaking of vaccine Reconstitution with incorrect diluent Drug substituted for vaccine or diluent e.g. insulin, oxytocin, muscle relaxants Reuse of reconstituted vaccine at subsequent session	Local abscess Vaccine ineffective <sup>a</sup> Negative effect of drug, shock, and death Vaccine ineffective <sup>a</sup>
Injection at incorrect site BCG given subcutaneously DTaP-IPV//Hib too superficial Injections into buttocks	Local reaction or abscess Local reaction or abscess Local reaction or abscess Sciatic nerve damage
Vaccine transportation/storage incorrect VVM changed colour Clumping of adsorbed vaccine	Vaccine ineffective <sup>a</sup> Local reaction from frozen vaccine
Contraindications ignored	Avoidable severe reaction
<b>a = A vaccine being ineffective is an “effect”, it is not strictly an adverse event</b>	

**Simple ways to improve injection safety**

- Prepare injections in a clean designated area.
- Do not reconstitute or prefill syringes before clients arrive.
- Never leave the needle in the top of the vaccine vial.
- Follow product-specific recommendations for use, storage and handling of vaccines.
- Follow safe procedures to reconstitute vaccines

- Make sure you have the CORRECT diluent for each freeze-dried vaccine — check that the same manufacturer produces both diluent and vaccine.
- When reconstituting, both the freeze-dried vaccine and the diluent must be at the same temperature (between 2°C and 8°C).
- Use a sterile syringe and needle to reconstitute each unit of vaccines. **Use all the diluent provided for the vial (even if it appears more than 5 mls on your syringe).** After use, place the syringe into a safety box.
- All BCG and measles vaccines should be discarded at the end of the session, or after six hours, whichever is sooner.
- Use a new syringe and needle for every child — preferably an auto-disable syringe.
  - Use a new, quality disable syringe and needle with each injection.
  - Inspect the packaging very carefully. Discard a needle and or syringe if the package has been punctured, torn or damaged in any way.
  - Do not touch any part of the needle. Discard a needle that has touched any non-sterile surface.

Hold the child firmly. Anticipate sudden movement during and after injection.

## Preventing needle stick injuries and infections

### Needles can be dangerous!

Needles frequently injure health workers. Small but dangerous amounts of blood infected with hepatitis B, hepatitis C, HIV, other viruses and or other microorganisms can be transmitted by needle stick injuries.

#### Needle stick injuries may occur:

- when health workers recap needles or walk while carrying used syringes and needles;
- if patients, especially children — are not positioned securely while they receive injections;
- If unsafe disposal practices leave people or animals exposed to used syringes and needles.

### **Prevent needle stick injuries by:**

- setting up the immunisation work area to reduce the risk of injury;
- minimising the need to handle needles and syringes;
- handling syringes and needles safely;
- positioning children correctly for injections; and
- Practicing safe disposal of all medical sharps and waste.

### **Minimise handling of used needles and syringes**

Needle stick injuries can occur at any time, but most frequently during and immediately after an injection is given. In general, the more the injection equipment is handled, the greater the risk of needle sticks injuries.

Needle stick injuries are preventable. There are simple steps health workers can follow to reduce the risk of needle stick injuries.

Minimising the need to handle injection equipment is crucial to prevent needle stick injuries.

Important practices that help to minimise handling.

- Place a safety box close to the person giving vaccinations so that used syringes and needles can be disposed of immediately.
- Avoid recapping the needle.
- Do not manually remove the used needle from the syringe.
- Do not carry used syringes and needles around the immunisation area or work site.
- When ready to vaccinate draw up the vaccine, inject the vaccine, and put the syringe in the safety box without putting it down between steps.
- Close the safety box securely when it is three-quarters full.
- Do not manually sort needles and syringes.

### **Handling syringes and needles safely**

You hold and touch only the syringe to give an injection. Any part of the syringe that you touch becomes contaminated, so you should not touch parts that come into contact with the vaccine or the child.

### **Do not touch:**

- the shaft of the needle;
- the bevel of the needle;

- the adaptor of the needle;
- the adaptor of the syringe; and
- The plunger seal of the syringe.

**Figure 11: Part of the syringe and needle that should not be touched**

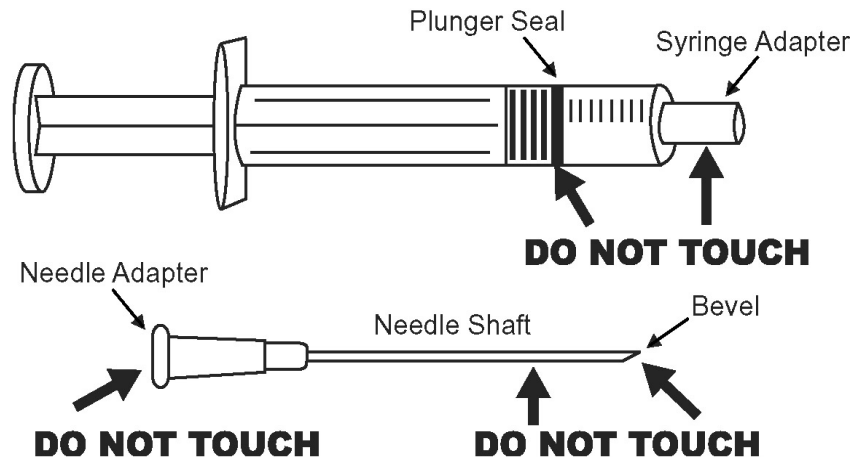

**IMPORTANT:** If you touch any of these parts, discard the syringe and needle and get new sterile ones.

You may touch:

- the barrel; and
- The plunger top.

**Figure 12: Parts of a syringe and needle that may be touched**

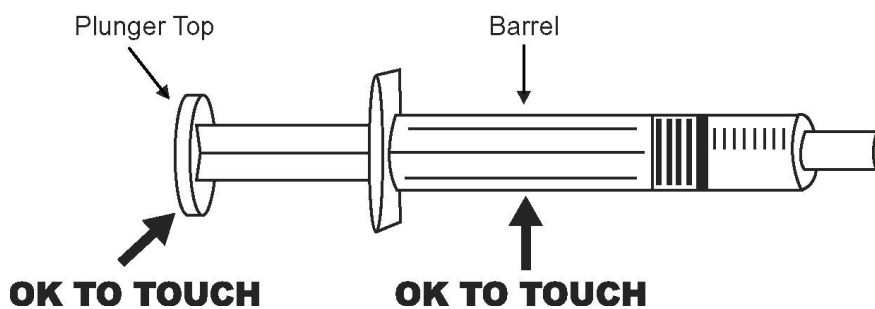

**Set up the immunisation work area to minimise the risk of injury**

**Health workers should plan the layout of their work space such that:**

- The vaccine carrier is in the shade.
- Tally sheets can easily be reached.
- Children are not exposed to and are not be within easy reach of needles and sharps.

- The safety box is within easy reach of the person giving the vaccine. Some people may stand when giving vaccines, in which case the safety box may be on the table. Those who sit may want to place the safety box on the floor.
- The vaccinator can dispose of used needles and syringes directly into the safety box.
- The vaccinator should only attend to one child at a time.

Each vaccinator should have his or her own safety box.

### **Positioning children correctly for injections**

Unexpected movement at the time of injection can lead to accidental needle stick injuries.

To prevent this, position the child securely before giving the injection.

- Have the mother sit and place the child on her lap.
- Make sure one of the mother's arms is behind the child's back, and one of the child's arms wraps around the mother's side.
- The mother may tuck the child's legs between her own to secure them, or she may hold the child's legs with the other hand.

**Figure 13: Correct position for a child receiving an injection**



- Health workers cannot hold a child because they need both hands for administering the injection.
- Always alert the mother when you are about to give the injection.



## **Disposing of used syringes and needles**

Injection equipment should be discarded immediately after use.

### **It is important to handle sharps waste properly.**

Sharps waste can cause serious health and environmental problems. Unsafe disposal can spread some of the very diseases you are working so hard to prevent.

### **Dangers to health**

Leaving used syringes and needles in the open or on the ground puts the community at risk. Most frequently, children are the unfortunate victims of needle stick injuries from unsafe disposal of needles.

### **Dangers to the environment**

Throwing used needles and syringes in a river contaminates water used for drinking and washing.

### **Using a Sharp Disposal safety box**

All used injection equipment should be placed in a **sharp disposal container or safety box** immediately after use. These containers are waterproof and tamper-proof and needles cannot easily pierce them.

#### **To ensure safe handling of the safety box:**

- Don not handle or shake the safety box more than necessary. Never squeeze, sit or stand on safety boxes.
- Take extra care when you carry the box to the disposal site. Hold the box by the top (by the handle provided) above the level of the needles and syringes.
- Keep safety boxes in a dry - safe place, out of reach of children and the general public, until they have been safely disposed of.
- Train everyone who will handle the box how to do it safely.
- Do not ask untrained staff to handle safety boxes.

## **Procedures for disposing of sharps waste**

All injection equipment must eventually be destroyed. **Disposable syringes and needles** are used once and then destroyed.

### **Step 1**

Place the safety box within reach of the health worker. After each injection, immediately place the syringe and needle in the safety box or sharps container. Do not recap needles.

### **Step 2**

Following the immunisation session or when the safety box is three-quarters full, close the container.

Do not transfer used syringes and needles from safety boxes to other containers.

A five litre safety box can hold about 100 syringes and needles. When three quarters full, it should be sealed and put away.

### **Step 3**

Find a safe place to store safety boxes until collected.

Used syringes and needles must NEVER be dumped in open areas where people might step on them or children might find them. They should never be disposed of along with other kinds of waste.

### **Monitoring and evaluation of injection safety**

Regular supervisory visits and monitoring are essential to ensure that safe injection practices are implemented. The following should be supervised in both routine and mass campaign settings:

- Adequate supplies of syringes, needles and safety boxes at each immunisation site.
- Needles and syringes are NOT recapped but are placed in a safety box immediately after use.
- The contents of the safety boxes are not tampered with or transferred to another container.
- Safety boxes should only be three-quarters full – not overfilled.

**Figure 14: Unsafe immunisation practices**



**Do not overfill the safety box**



**Do not recap the needle**



**Do not leave the needle inside the vial**



**Do not touch the needle**



**Do not dispose of used needles in an open cardboard box**

## MODULE 9: ADVERSE EVENTS FOLLOWING IMMUNISATION (AEFIs)

---

### BACKGROUND

An Adverse Event Following Immunisation (AEFI) is a medical incident that takes place after immunisation, it causes concern and is believed to have been caused by immunisation.

*Modern vaccines are safe* and all vaccine batches used in the immunisation programme in South Africa are thoroughly tested before being released. However, no drug and thus no vaccine are absolutely without risk. As vaccine preventable diseases become less frequent as a result of effective immunisation programmes, more attention will focus on AEFI. Severe adverse events associated with the use of vaccines may become a serious threat to the programme and may dent public confidence in the immunisation programme. The low level of tolerance to adverse events caused by immunisation may be due to the fact that vaccines are administered to healthy infants and the health officials and workers insist that children should be vaccinated.

Vaccines mimic the disease being prevented to stimulate the immune system. Vaccination may thus result in symptoms which are similar to the disease being prevented, but much milder. These normally settle on their own, and should be no cause for concern. It is important to warn parents of these reactions, advise on how to manage minor reactions and when to return to the health facility.

Mild symptoms such as slight fever, redness or swelling at the injection site are common. Major and severe reactions, which include life - threatening events are very rare. Every case of a severe reaction should be investigated to determine the cause. Should immunisation be responsible for the event, an in - depth investigation of the case focusing on the programme must be conducted to ensure that further unnecessary adverse reactions will be prevented. Prompt response and investigation of an AEFI are important for the immunisation programme to maintain public confidence in immunisation.

Adverse events can be classified into 2 major groups; Local and Systemic.

**Mild systemic symptoms** include; irritability, mild fever as well as minor local symptoms of redness/swelling at injection site are quite common. These need not be reported. The more severe reactions, which are rare, should always be reported. See the table below of the adverse reactions that should be reported.

Adverse reactions can also be classified according to the cause of the adverse reaction like; vaccine reaction, programme error, coincidental and unknown.

**Table 9.1: Classification of AEFI by the cause**

Cause	Description
Vaccine related	Event is caused or precipitated by the vaccine when given correctly, caused by the inherent properties of the vaccine.
Programme error	Event is caused by an error in vaccine preparation, handling or administration.
Coincidental	Event that happens after immunisation but is not caused by the vaccine – a chance association.
Unknown	The cause of the event cause cannot be determined

## ADVERSE EVENTS WHICH SHOULD BE REPORTED

**Table 9.2 : AEFI, which should be reported**

Local Reactions	<ul style="list-style-type: none"> <li>• All cases of BCG lymphadenitis</li> <li>• All injection site abscesses</li> <li>• Severe local reactions with swelling further than 5 cm from injection site, or pain, redness and swelling of more than 3 days duration</li> </ul>
Systemic and Severe Reactions	<ul style="list-style-type: none"> <li>• All cases of hospitalisation thought to be related to immunisation</li> <li>• Collapse or shock-like state within 48 hours of DTaP-IPV//Hib</li> <li>• Anaphylaxis</li> <li>• Encephalopathy within 7 days of DTaP-IPV//Hib</li> <li>• Fever of 39°C or more within 48 hours of DTaP-IPV//Hib</li> <li>• Seizures within 3 days of DTaP-IPV//Hib</li> <li>• All deaths thought to be related to Immunisation</li> <li>• Vaccine Associated Paralytic Polio (VAPP), which is paralysis within 30 to 40 days of oral polio vaccine. This should be reported as an acute flaccid paralysis (AFP)</li> </ul>

## AEFI that have been described

**Table 9.3 Types of Adverse Events Following Immunisation by the vaccine given**

Vaccine	Reaction	Onset interval	Rate per Million doses
Measles	Febrile seizures	5-12 days	333
MMR	Thrombocytopenia	15-35 days	33
	Anaphylaxis	0-1 hr	1-50
OPV	Vaccine associate Paralytic Poliomyelitis (VAPP)	4-30 days	0,76 –1,3 ( 1 <sup>st</sup> dose) 0,17 (subsequent doses)
	Anaphylaxis	0-1 hr	1-2
Hep. B	Gullian Barre Syndrome	0-2 1-6 weeks	5
	Anaphylaxis	0-1 hr	5-10
Td same as TT	Sterile Abscess	1-6 weeks	1-10
	Suppurative lymphadenitis	2-6 months	100 – 1000
BCG	BCG osteitis	1-12 months	1-700
	Disseminated BCG	1-12 months	2
	Persistent screaming	0-4 hrs	1000 – 60 000
DTaP-IPV//Hib	Seizures	0-3 days	570
	Anaphylaxis/shock	0-1 hr	20
	Encephalopathy	0-3 days	0-1

## CASE DEFINITIONS AND THE MANAGEMENT OF SPECIFIC AEFIS

### Anaphylaxis

Anaphylaxis, commonly referred to as anaphylactic shock is a very severe immediate allergic reaction that may occur after an injection or an exposure to any allergen. Clinical features include:

- Collapse with shock
- Bronchospasm
- Laryngeal oedema

Theoretically any vaccine injection may lead to anaphylaxis. Anaphylaxis after immunisation (although quite rare - 1/1000,000 vaccinations) has been associated with; measles, Hepatitis B, DTaP-IPV//Hib and DT.

A fully equipped, regularly checked emergency tray should always be available close to the vaccinator, to deal with anaphylactic reactions. Ensure that the emergency tray has paediatric size resuscitation equipment and the drugs have not expired.

Anaphylaxis may be confused with faints, which are relatively common after immunisation of adults and adolescents but very rare in young children. A strong central pulse (like carotid) is maintained during a faint but not in anaphylaxis. Administration of adrenaline in a patient who has fainted may be dangerous.

**Be prepared for an anaphylactic reaction after immunisation, even though it is rare:**

- Always keep a fully equipped emergency tray at the immunisation point.
- A health worker providing immunisation should be trained on appropriate management of an anaphylactic reaction.
- The recommended standard treatment guidelines for anaphylaxis should be followed
- Emergency equipment should be checked regularly.
- Make sure the equipment and drugs on the emergency tray provides for paediatric (infants and children) and adult emergencies.
- Follow the Essential Drugs List (EDL) guidelines for the management and treatment of anaphylaxis.

**Table 9.4: Other AEFI: case definitions and management**

Adverse Event	Case Definition	Treatment	Vaccine
Fever	Fever can be classified (based on the rectal temperature) as mild 38 –38.9°C) or high (39 – 40, 4 °C) and extreme 40.5 °C or higher).  May be associated with irritability malaise and systematic symptoms.	Symptomatic, give extra fluids tepid sponge and paracetamol	All

Adverse Event	Case Definition	Treatment	Vaccine
Acute Flaccid Paralysis (Vaccine Associated Paralytic Poliomyelitis =VAPP).	Acute onset of flaccid paralysis within 4 to 40 days of receipt of oral poliovirus vaccine (OPV), or within 4 to 75 days after contact with recipient and neurological deficits remaining 60 days after onset, or death.	No specific treatment available: supportive care.	OPV
Disseminate BCG infections	Widespread infection occurring within 1 to 12 months after BCG vaccination and confirmed by isolation of <i>Mycobacterium Bovis</i> BCG strain. Usually in immunocompromised individuals.	Should be treated with anti-tuberculosis regimens including isoniazid and rifampicin.	BCG
Encephalopathy	<p>Acute onset of a major illness characterised by any two of the following three conditions:</p> <ul style="list-style-type: none"> <li>- Seizures</li> <li>- Severe alteration in level of consciousness lasting for one day or more</li> <li>- Distinct change in behaviour lasting one day or more.</li> </ul> <p>Needs to occur within 48 hours of DTaP-IPV//Hib vaccine or from 7 to 12 days after measles or MMR vaccine, to be related to immunisation</p>	No specific treatment available; supportive care.	Measles, Pertussis



Adverse Event	Case Definition	Treatment	Vaccine
Hypotonic, hyporesponsive episode (HHE or shock-collapse)	Event can be sudden onset occurring within 48 [usually less than 12] hours of vaccination and lasting from one minute to several hours, in children younger than 10 years of age. All of the following must be present: <ul style="list-style-type: none"> <li>- Limpness (hypotonic)</li> <li>- Reduced responsiveness</li> <li>- Pallor or cyanosis – or failure to observe/ recall</li> </ul>	The episode is transient and self-limiting, and does not require specific treatment. It is <b>not</b> a contraindication to further doses of the vaccine.	Mainly DTaP-IPV//Hib, rarely others
Injection site abscess	Fluctuant or draining fluid-filled lesion at the site of injection. <b>Bacterial</b> if evidence of infection (e.g. purulent, inflammatory signs, fever culture), <b>sterile</b> abscess if not.	Incise and drain; antibiotics if bacterial.	All
Osteitis/Osteomyelitis	Inflammation of the bone with isolation of <i>Mycobacterium Bovis</i> : BCG strain.	Should be treated with anti-tuberculous regimens including isoniazid and rifampicin.	BCG
Lymphadenitis includes (suppurative lymphadenitis)	At least one lymph node enlarged to over 1.5 cm in size or a draining sinus over a lymph node. Almost exclusively caused by BCG. This condition occurs 2-6 months after BCG vaccination on the same side as inoculation (most axillary).	Heals spontaneously over months. Best not to treat, unless sticking to skin or draining. Surgical drainage and local instillation of anti-tuberculous drugs. Systemic treatment with Anti-TB treatment not effective	BCG
Persistent inconsolable screaming	Inconsolable continuous crying lasting 3 hours or longer accompanied by high-pitched screaming.	Settles within a day or so; analgesics may help.	DTaP-IPV//Hib,

<b>Adverse Event</b>	<b>Case Definition</b>	<b>Treatment</b>	<b>Vaccine</b>
Severe Local reactions	Redness and/or swelling centred at the site of injection and one or more of the following: swelling beyond the nearest joint, pain, redness, and swelling of more than 3 days duration. Requires hospitalisation Local reactions of lesser intensity occur commonly and are trivial and do not need to be reported.	Settles spontaneously within a few days to a week. Symptomatic treatment with analgesics. Antibiotics are inappropriate.	All
Toxic shock syndrome(TSS)	Abrupt onset of fever, vomiting and watery diarrhoea within a few hours of immunisation. Often leading to death within 24 to 48 hours. Needs to be reported as possible indicator of programme error.	Critical to recognise and treat early. Urgent transfer to hospital for parenteral antibiotics and fluids.	
Seizures	Occurrence of generalised convulsions that are not accompanied by focal neurological signs. Febrile seizures: if rectal temp 38°C. Afebrile seizure: no associated temperature.	Usually self limiting, supportive with paracetamol and cooling if febrile	DTaP-IPV//Hib, Measles
Intussusception	Severe abdominal pain, persistent vomiting, bloody stools, abdominal bloating and/or high fever	Needs surgical intervention in most cases	<b>Rotavirus</b>

## **SURVEILLANCE FOR ADVERSE EVENTS FOLLOWING IMMUNISATION (AEFI)**

The primary aim of Surveillance for AEFI is to increase immunisation acceptance and improve the quality of services. Whatever the cause, when an adverse event following immunisation upsets people to such an extent that they refuse further immunisation for their children, the children are more likely to get a vaccine preventable disease, become seriously ill, disabled and even die. The surveillance for AEFI must become an integral part of the immunisation programme.

South Africa is conducting surveillance for AEFI. This surveillance is linked to surveillance for Acute Flaccid Paralysis (AFP), neonatal tetanus and suspected measles cases. Details of AEFI surveillance can be found in the Field Guide for EPI Target Diseases published by the NDoH.

### **AEFI surveillance steps**

There are 5 major steps in the surveillance of AEFI:

- Detecting and reporting
- Investigating
- Collation and analysis of the data
- Corrective measures and other actions
- Evaluate your surveillance and the handling of cases

### **Detecting and reporting AEFI**

The list of all AEFI which should be reported and have the case investigation form filled, are given earlier in this chapter. All deaths, hospitalisation and other severe unusual medical incidents which have occurred within a month of immunisation and are thought by health workers and/or the public to be related to immunisation should be reported. Other similar incidents with delayed onset thought by health workers or the public to be related to immunisation should also be reported.

All AEFI or such incidents, which should be reported, are at times called trigger events, because their presence stimulates or triggers a response.

## **Who should report AEFI?**

The detection of AEFIs is the responsibility of:

- All Health Care Workers providing immunisation services
- Health Workers providing clinical treatment of AEFI in health centres, hospitals etc
- Parents who report AEFI affecting their children
- Researchers conducting clinical trials or field trails

## **To whom should AEFI be reported?**

Health workers at facility level should report all AEFI to the sub-district or district office. Serious AEFI e.g. death and hospitalisation should also be reported immediately, directly to the provincial EPI manager. A case investigation form for AEFI should be filled for all cases (see Annexure 7).

Routine surveillance reports that include surveillance for other conditions should be submitted by each sub-district to the district office on a monthly basis even when there is no condition detected (zero reporting). The district supervisor will then compile a report for reporting to a higher level.

Supervisors should monitor the number of cases that have been reported by each facility each month. This information should be kept up to date to help establish:

- If the same kind of event is occurring in the same health centre every month
- If different health centres are reporting the same kind of AEFI
- If the AEFI reported by different facilities are comparable.

In this way supervisors can identify patterns such as clusters within or across health centres and take appropriate action.

## **Investigating AEFI**

The report of an AEFI should be followed by a case investigation or by a series of case investigations when there is a cluster of AEFIs.

The ultimate goal of case investigation is to find the cause of an AEFI or a cluster of AEFI and correct it. If the cause is programme error remedial action can be taken promptly, and the public assured of the integrity of the immunisation services.

### **The purpose of investigating an AEFI is:**

- To confirm a reported diagnosis or propose other possible diagnoses and clarify the outcome of the medical incident or incidents.
- To establish the details on the vaccines used to immunise the patient or patients.
- To examine the operational aspects of the programme. Even if the AEFI seems to be coincidental, programme errors may have increased its severity.
- To determine whether a reported event was a single incident or a cluster of incidents.
- To determine whether unimmunised people are experiencing the same medical incidents.

### **What should be investigated and when?**

All trigger events should be reported

- All injection site abscesses.
- All cases of BCG lymphadenitis.
- All deaths that occur within one month of immunisation.
- All cases which require hospitalisation that occur within one month of immunisation.
- All medical incidents that are believed to have been caused by immunisation and about which people are concerned.

Investigation should begin as soon as possible, ideally within 24 hours of detection by a health worker but not later than 48 hours. An investigation conducted timely may identify programme errors, correct them before other people are exposed to the same error and show the community that their health and concerns are taken seriously.

### **Who should be involved in the AEFI investigation?**

Serious AEFI should be investigated by trained health workers from the district and provincial/national office. It is best that each district forms a standing AEFI investigation team that will investigate AEFI. Each AEFI team should include the following:

- EPI co-coordinator/ manager.
- Vaccine logistics/Cold chain co-coordinator.
- District pharmacist (if the co-coordinator is not a pharmacist).
- Referral hospital paediatrician/clinician.
- Communication's officer – media and community liaison.

- Community nurse.
- Epidemiologist.

The following may be included:

- Clinical psychologists of the area.
- District surgeon, in case of death he may be involved in the inquest and the post mortem.

The vaccinator (who administered the specific vaccine dose) should be excluded from the case *investigation team* but not from the *investigation process*.

### What data should be collected?

For case or cluster investigations the following data should be collected:

- **Data on the patient**
  - Demographic data about the patient including a unique case number.
  - History of patient's present illness – symptoms, when they appeared, the duration, treatment outcome and diagnosis.
  - History of patient's past illness – reactions to previous doses, drug allergies, pre-existing neurological disorders and current medications.
  - Immunisation history – vaccine, number of doses received, dates, place of last immunisation and injection sites.
  - Laboratory results about blood, stools & other samples if appropriate.
- **Data on the vaccine administered**
  - Batch number.
  - Expiry date.
  - Manufacturer.
  - When and from where the vaccine was received.
  - Condition of vaccine on receipt – e.g. was it reconstituted, cold chain etc.
  - Laboratory results about the vaccine if appropriate.
- **Programme related data**
  - Common practices followed by health workers in
    - Storing vaccines
    - Handling vaccines during sessions and after sessions
  - Common practices in reconstitution of vaccines
    - Are correct & sterile diluents used

- Are correct doses given
  - Are correct routes used
  - Availability of needles and syringes
  - Is one sterile needle and one sterile syringe used for each injection?
- **Data on the people in the area**
  - The number of people who were vaccinated from the same lot during the same immunisation sessions.
  - The number of those people who fell ill and their symptoms.
  - The number of people who were vaccinated or not vaccinated from a different lot or batch of vaccine who fell ill with similar symptoms.
- **Name of health worker who gave the immunisation**
  - All this data should be entered on the AEFI form; additional information should be attached as an annexure to the form.

#### **From whom should data be collected?**

- Patients who have had an AEFI should have a medical examination.
- The vaccinator and supervisors: Health worker (vaccinator) who administered the vaccine to the affected patient/s and during suspected sessions should be interviewed. Supervisors should be asked about immunisation practice problems in the past.
- Observation of sessions in the health facility concerned, particularly with the same health workers whose clients are affected might reveal the cause, since bad practices may be repeated.
- Affected Family/Crèche/Home: Investigators should visit the family/crèche/home or any other institution where the child attended up to the time of the incident. Interviews of parents, child minders, caregivers and other family/crèche members should be conducted.
- The investigation should elicit the events and sequence of events, medical history, treatment and any other observations prior to immunisation, during immunisation immediately after immunisation up to the time of investigation.
- Community members: Investigators should talk to the community members and other parents who might have been present during the vaccination session about what they might have seen.

- The public is asked to report incidents of the same symptoms or any other incident, which causes concern.
- Investigators need to explain to health workers, parents and others that although every effort is made to find the cause, the actual cause may never be found.

### **How should data be collected?**

Methods for data collection include: clinical examinations; interviews; review of patient records; and clinic registers/records; laboratory results; observation of administration of vaccines, vaccine handling and storage.

### **The role of the laboratory in the case investigation?**

Laboratories have an important role to diagnose or confirm a diagnosis of a medical condition. In the investigation of AEFI, laboratory analysis is rarely the key factor in the investigation. Laboratories may have a role in the following:

- Identify if the vaccine in the vial is the one the label says it is.
- Identify whether the vaccine being tested has been frozen or contaminated.
- Diagnose a condition which might explain the AEFI, e.g. hypoglycaemia – explain the mistaken use of insulin.
- Diagnose another condition in the patient, which will make the AEFI coincidental.

### **Specimens to send to the laboratory**

The samples that will be sent to the laboratory if any, will depend on the working hypothesis for the cause of the event. **Laboratory testing should be requested on a clear suspicion and not as routine. Under no circumstances should a vaccine be sent for testing before the case investigation has been conducted and a working hypothesis formulated.** Quite often the vial used on the day of the event is long discarded and thus not available. If available it should be sent with unused vials of the same lot. Vials from the same lot will be sent for testing if the used vial is no longer available, although the value of the findings will be weakened.



**Table 9.5: Laboratory testing to investigate AEFI by working hypothesis**

<b>Working Hypothesis – Programme related error suspected</b>	<b>Specimens to send</b>	<b>Laboratory Test</b>
Vaccine transportation or storage	Vaccine vial	Composition/ frozen vaccine
Reconstitution error	Vaccine vial & diluent	Sterility and chemical composition
Non sterile injection	Needle, syringe, vaccine vial & diluent	Sterility
Vaccine problem	Vaccine vial	Composition

**Laboratory investigations for AEFI are conducted by 1 laboratory in South Africa, the National Control Laboratory in Bloemfontein in the Free State province, which conducts batch tests for all vaccines before distribution.** For all cases of AEFI, which need laboratory investigation, the national office must be contacted to enlist necessary help with respect to transportation of specimen and making the arrangements for testing at the National Control Laboratory.

#### **How should data be recorded?**

Three kinds of records are important: the AEFI case investigation form, event description report and the line list - in case of clusters.

**AEFI case investigation form** – provides a record of important data about a patient that is available at the facility where the case is being detected. The health worker who detects the AEFI should start filling the form as soon as possible after learning of/detecting the case. The form should be completely filled with all the necessary information, as the form requires. See the Appendix for Case Investigating forms

**A line list** – is a list of all persons suffering an AEFI and investigated during a reporting period – of one month. At the district level the manager or co-coordinator responsible for AEFI prepares the line list, based on the reports of cases in the district.

On one line, information is written about each case. It includes the case number, the patient's name, address, date and place of immunisation, the vaccine/s used, manufacturer, batch number, symptoms and the date of onset of the event. Line list information is useful for identifying clusters and or other patterns for further investigation and follow-up action.

**The event description report** – provides a historical record of the AEFI and summarises the findings about a single event. No special form is needed for this report. During case investigation additional information, over and above what the case investigating form requires should be collected and recorded as part of the event description report.

### **What happens next?**

After an AEFI or a cluster has been investigated and the community searched for other cases, data are compiled and reviewed, a diagnosis made and a probable cause designated.

### **Analysing AEFI Data**

Analysing the data consists of reviewing the case investigation reports for each patient, reviewing other data about the event in the community in which it took place, making a final diagnosis and identifying the probable cause. It may not be possible to identify a cause, or there might be more than one cause, however managers should try to get as much information as it is possible from the data.

The AEFI team should conduct the analysis. For severe cases including death or permanent disability, a special AEFI committee elected at the national or provincial office will conduct the analysis and establish the cause of the event. This committee will also compile a final report on the incident and the series of events, which led to the AEFI. In case of a death, the report from the committee will be submitted to the Director-General for Health and the Minister of Health at the National Department of Health.

### **Making the diagnosis**

The diagnosis is usually made by; the health worker who detects the case, by a physician in hospital where the patient was referred or by a specifically trained investigator. In severe cases where the committee has been involved, the AEFI committee determines the final diagnosis. The patient's signs and symptoms, the history of the medical incident that precipitated the enquiry, the patient's past medical history, data on the suspected immunisation and laboratory results including post mortem results (where applicable) contribute to the diagnosis.

## **Determining the cause**

Until the investigation is complete, a working hypothesis is all that can be formulated. Causes of AEFI are classified into 4 groups: programme related, vaccine induced, coincidental and unknown. For some medical events a diagnosis itself tells the cause of the event e.g. abscess formation – programme related. In the case of anaphylaxis and vaccine associated paralytic polio (VAPP) the cause is vaccine related.

**Programme related AEFI** are common, they are related to programme errors rather than any other cause. The analyst should first examine the data for evidence of any errors in the storage, handling or administration of vaccines. For any AEFI the assumption should initially be that it is programme related, thus allowing for a thorough investigation into the programme to ensure a high standard of immunisation practice.

Look for evidence of the following errors:

Too much vaccine, incorrect reconstitution, wrong site, drugs substituted for vaccine or diluent, incorrect diluent and ignored contraindications etc.

**Vaccine Induced AEFI** are caused by the reaction of a particular individual to a particular vaccine. Because this is a personal medical incident it is highly unlikely that more than one person will have a vaccine-induced reaction to the same drug in the same session. The vaccine induced category includes the very rare vaccine precipitated events, which are medical incidents that would have occurred in the individual at some time but occurred sooner because of immunisation e.g. simple febrile seizure in a child with a family history of febrile seizures. BCG lymphadenitis and encephalopathy following BCG and DTaP-IPV//Hib respectively, are examples of vaccine induced AEFIs.

**Coincidental AEFIs** are caused by something other than programme errors and individual reactions to vaccines. This medical incident would have occurred even if the individual had not been vaccinated. The best evidence to support a conclusion that a medical incident is coincidental is that the same event has been diagnosed in people who have not been immunised.

**Coincidental AEFIs** are caused by something other than programme errors and individual reaction to vaccines. They are not related to immunisation or the vaccine in any way, except for the time that they occur.

**Unknown:** These have no known cause.

### **How should results of a case investigation be reported?**

After data has been analysed, the analyst will prepare a description report on the findings.

In case of a single AEFI, the analyst will give a report which includes; an event description, an account of the investigation, all the tests conducted if any, the diagnosis, give reasons for the diagnosis and describe the cause or possible causes of the AEFI.

In the case of a cluster the report will include all the components of a single case report plus the following:

- The number of people identified with the same AEFI.
- The suspected antigen.
- Common symptoms.
- The number of people vaccinated with the same vaccine batch/lot.
- The name/s of the health facility/facilities where the affected people were immunised.
- Whether all facilities involved used the same vaccine batch/lot.
- How many immunised people in the same community/ from same health facilities had the same symptoms?
- The average time period between the immunisation and the onset of the symptoms.
- The immunisation practices in the facilities involved.
- Laboratory findings if appropriate.

In all reports for single or cluster of cases, the event description report should provide a brief history of the event including but not limited to:

- Who reported the AEFI and when.
- Who conducted the case investigation?
- When the investigation began.
- How the investigation was conducted.
- Which laboratory was used?

Supporting data like the case investigation form and laboratory reports should be appended to the report.

Despite proper investigation and analysis, sometimes no cause for an AEFI is found, or the cause may be determined to be unrelated, possibly related or probably related to immunisation.

Managers should use the reports not only to determine what actions to take, but to evaluate the effectiveness of the system in responding to AEFIs and to improve the immunisation services.

### **Immunisation of special populations**

Special care and consideration has to be taken when vaccinating people affected by certain conditions. In some of the conditions the vaccine may not work optimally, i.e. the individual may only produce a lower level of antibody titres than a normal person. Vaccine related events are more likely to occur amongst these special populations, particularly if they have received live attenuated vaccines. Such populations include, but not limited to immuno-compromised patients due to:

- Human Immunodeficiency Virus (HIV)
- Congenital Immunological Dysfunction
- Immunosuppression, e.g. from steroids, chemotherapy etc.

In this group of people, the risk of disseminated infections from live attenuated vaccines is high; it is thus recommended that vaccination with live attenuated vaccines should not be given except after consultation with the attending physician.

### **Contraindications (CI)**

Giving vaccines in the presence of contraindications (CI) may increase the likelihood of AEFI. It is recommended that vaccinators follow these guidelines on contraindications.

A child with current serious febrile illness.	Delay vaccine administration
History of severe AEFI after a previous dose	Do not give that specific vaccine
Evolving neurological disease e.g. epilepsy	Avoid pertussis vaccine
Symptomatic HIV/AIDS	Avoid BCG, Measles and OPV
Objection of a care giver to vaccination	Do not vaccinate.

## **TAKING ACTION ON ADVERSE EVENTS FOLLOWING IMMUNISATION**

AEFI detection, investigation and analysis must lead to action if the credibility of immunisation services is to remain high. These actions include: investigation, diagnosis, treatment, reporting, communication and **correction of programme errors**.

### **Action by peripheral health workers at Primary Health Care Facilities**

Even though serious AEFIs are rare, the peripheral health worker must know what to do when faced with a serious AEFI. Health care workers need to know how to diagnose, treat or refer serious AEFIs. They should report a serious AEFI immediately after detection.

Fortunately, serious AEFIs are rare events, and the average peripheral health worker may never see one. They are much more likely to see less serious AEFIs such as abscesses, redness at the injection site or lymphadenitis. Ideally, each event should be listed on a form such as the line list form. However, staff may be reluctant to report to a superior such events, fearing they will be penalised for “poor vaccination technique”.

EPI-SA encourages a mutually trusting relationship where health workers feel confident to report such incidents to their supervisors, and the supervisors will support them in correcting any programme error, which might be contributing to the incidents. Actions taken by peripheral health workers are set out below and summarised in the flow chart on the opposite page.

Severe AEFI must be immediately referred for higher level of care. This must be amongst the first response to an AEFI. Mild symptoms such as fever are likely to be of short duration, and can be treated by parents or health workers.

Communication with the parents, health workers not involved in the investigation and other people in the community must take place irrespective of the circumstances of the event. Rumours or public inquiries must be responded to. This is particularly important when public anxiety is high.

**Figure 12: Taking action by Peripheral Level Health Worker**

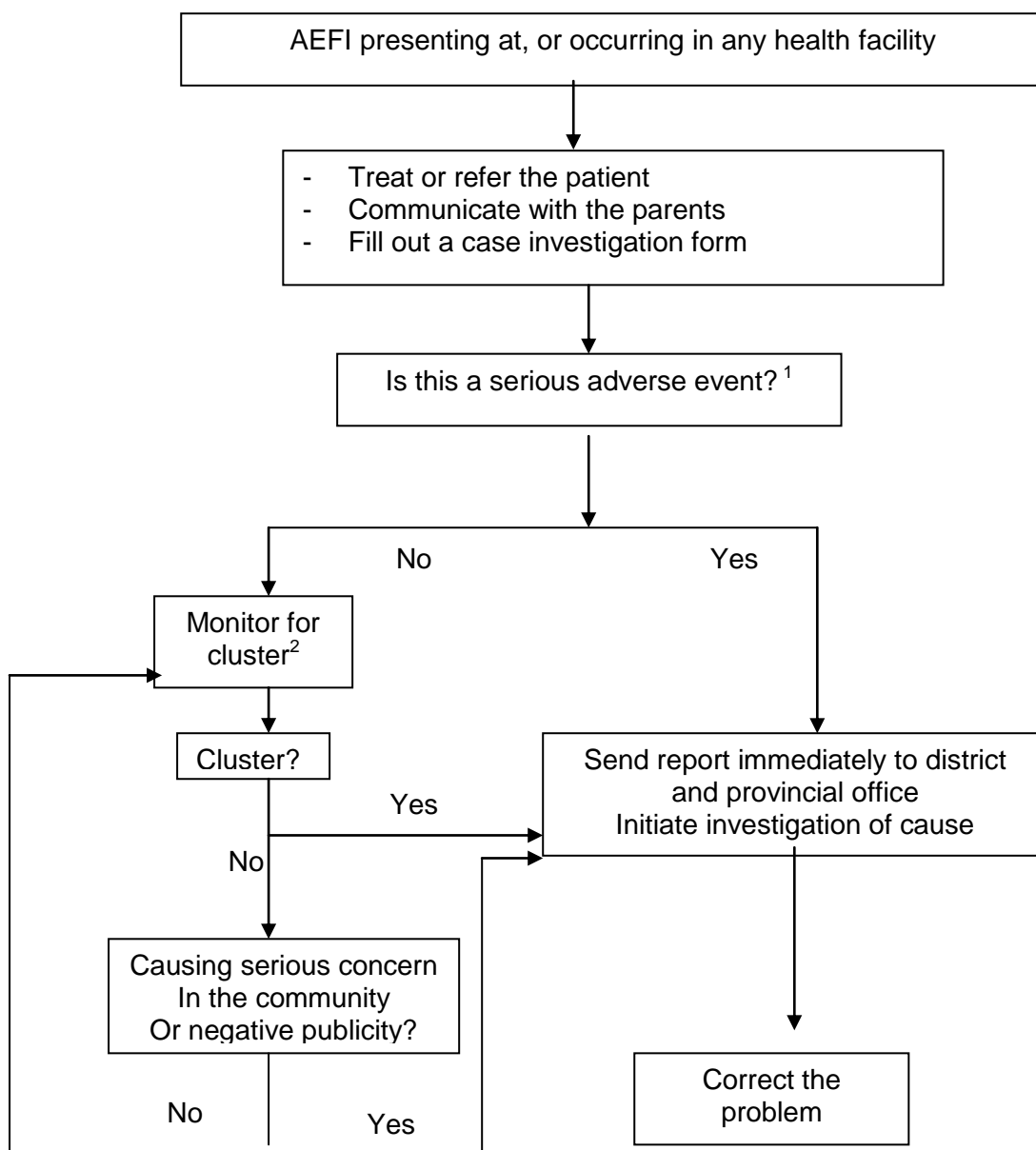

<sup>1</sup> Defined as serious if it results in death or hospitalisation.

<sup>2</sup> A cluster is defined as AEFIs which occur with unusual frequency, by vaccine, by type of reaction, or by locality/facility. A more precise definition may be decided upon by national programme managers.

## **Reporting AEFI**

EPI-SA recommends that all facilities should keep the case investigating forms, which will be filled for every case of AEFI. Line listing should be drawn up for cluster cases and at the end of each year.

A serious AEFI (death or hospitalisation) should be reported to the district manager and provincial office immediately by the quickest means (telephone, fax). At the same time a case investigation form should be completed and dispatched as soon as possible.

Following a non-serious AEFI, the health worker should monitor for clustering. Evidence of clustering (AEFIs occurring with unusual frequency, by vaccine, by type of reaction, or by locality / facility) should be reported immediately. Even isolated AEFI should be reported immediately if they are causing concern to the public.

## **Corrective action**

Peripheral health workers may initiate corrective action themselves if it is clear what to do (eg. improve safe injection practices in the case of an abscess). However, corrective action will usually be in response to guidance from the district manager or other staff member at a higher level.

## **Role of the district co-coordinator**

### **Training**

Staff should be trained to respond to AEFI, and to differentiate between mild, non-significant reactions and more serious events. Typical non-significant reaction to vaccines include fever, redness or swelling at the injection site, and rash. Remember, children in the immunisation age group may have unrelated symptoms due to common infections at the same time. Training must be designed so that the health worker can practice the relevant skills until mastery.

### **Supervision**

Non-serious AEFI (like abscesses) reported by health workers should be supervised by site visits. Supervisors should give immediate feedback to health workers on the AEFI and on their routine surveillance, case investigation and other reports.



### **Investigation and collection of data**

The district co-ordinator should stock investigating forms and distribute as needed. Clusters of non-serious AEFI should be investigated and a decision taken whether to report them to a higher level. Following a report of serious AEFI, the district managers should be responsible for investigation, collection and reporting of data. This may be under the overall supervision of a national team.

### **Correction of the problem**

If an AEFI was caused by a programme error (such as improper handling of vaccines or faulty immunisation technique) the actions to be taken will probably include one or more of the following:

#### **Logistics**

Improving logistics will be the appropriate response if programme errors can be traced to the lack of supplies or equipment or to a failure in the cold chain. Managers should investigate suspected breaks in the cold chain to find the cause and take appropriate measures. These might include training or supervision or the problem might be solved by providing more or better supplies (needles, syringes, vaccine carriers, cold packs) or by providing more vaccine or diluent.

#### **Training**

Solving operational problems through training will deal with lack of skills and knowledge and poor attitude. Effective immunisation services call for health workers who can detect AEFIs and provide immunisation services safely and who care about doing so. When an AEFI has been caused or made worse by service delivery errors and the investigator identifies the specific error, training can focus on correcting that error. If the investigator tracks an error to one health worker, that health worker's immunisation activities should be terminated immediately, at least until he or she masters the missing skill.

#### **Supervision**

Wherever AEFI are reported, supervision should be intensified. Supervisors throughout the country should watch for any problem that has caused a cluster of AEFI. If previous training or supervision on the relevant skills has been weak, the problem could be widespread.

## Communication Around Adverse Events

When an apparently healthy infant who has recently been immunised, suddenly dies and there is not an obvious cause for the death, the timing of the two events (death & vaccination) is immediately associated. The sequence of the two events is often perceived to indicate a causal relationship – it is assumed that the immunisation caused the event because the two events are related in time. It is therefore crucial that a proper and unbiased investigation takes place to consider all the possible causes in a systematic manner.

The district manager, the provincial EPI manager (national EPI manager in case of death) and a communication officer for the department of health should set up means for continuous communication between health workers (investigators, peripheral health workers, supervisors, managers) and the community, directly and through the press. The public should be informed frequently about what is being done during an investigation. When the investigation is over, conclusions and recommendations should be shared, and the public informed of the findings and measures taken to remedy any problems found.

**The key to maintaining confidence in health services is to be honest.** If the cause of the AEFI has not been identified, the public should be informed. Emphasise that the event remains suspected until the completion of the full investigation into the possible causes.

If the cause has been related to programme errors, the actions being taken to remedy the problem should be explained. When death occurs because of a programme error, special precautions may have to be taken to protect health workers from harm by the community. Health workers who are implicated in the error might have to be removed from the scene before the findings are communicated.

A vaccine-induced AEFI presents a challenge and needs to be communicated in a sensitive and skilful manner. The public needs to be assured that severe vaccine-induced events are rare, even though this may not comfort the patient's family. In some cases, managers may find it appropriate to provide information on the low incidence of these events. In many contexts however, statistics may be almost meaningless and the best that can be done is to show genuine sympathy and concern.

The period between the reporting and the completion of the investigation, should be kept as short as possible to maintain public confidence in immunisation. The appropriate response during this period includes the communication of risk - benefit information to the parents, members of the community, the media and the concerned health workers.

Unfortunately the event is often most newsworthy immediately after the event is reported, giving rise to rumours which may dent public confidence in the immunisation services. Attention is seldom given to the outcome of the investigation or to the fact that there is an alternative cause for the event, which is usually the case. News items entitled “killer vaccines” and “a shot in the dark” have a negative impact on the EPI programme. These may be one of the reasons for some parents not to bring their children for immunisation.

**Important points to consider when planning a response to a serious AEFI report:**

- Vaccinators should be well informed about vaccines and immunisation and be seen to be a good source of authoritative and scientifically justified advice.
- Discuss both the benefits and risks of vaccination so that parents and communities have a full understanding of all the issues.
- Parents should also be assisted to understand the benefits and risks if they do not have their children vaccinated.
- Parents have the right to know. Honesty is important to maintain the credibility of immunisation as an effective means of preventing targeted diseases
- Vaccinators should be positive about immunisation, as their attitudes have been found to be a major influence on parents and clients.

Consult Module 10 – Social Mobilisation

For more information to assist with risk-benefit communication about immunisation

## MODULE 10: SOCIAL MOBILISATION, ADVOCACY AND COMMUNICATION FOR EPI

---

### BACKGROUND

A Successful EPI relies on commitment and continuous support from community leaders, politicians and decision-makers, health professionals, the public and the media.

#### Advocacy

It is important that decision-makers understand the true value of immunisation so that when they allocate resources, EPI can receive a fair portion. Sometimes people are tempted, or coerced, to fund public relations over public health, to choose curative services over preventive services, or to select the quick fix over longer-term (and more sustainable) solutions.

In some ways, immunisation can be a victim of its own success. If decision-makers believe that the EPI program achieved the universal childhood immunisation targets set for 1990, they may assume that the program is still functioning well today. Furthermore the noticeable decline in the incidence of vaccine preventable diseases may convince the decision makers that it is not worthwhile to invest in immunisation. Yet we know for a fact that where immunisation coverage has declined to low levels, vaccine preventable diseases have re-emerged in epidemic proportions affecting thousands of people, causing a number of disabilities and deaths.

In some areas of South Africa, immunisation coverage rates may have declined or remained stagnant over the last decade. Furthermore, now that new vaccines are available, the definition of a “fully immunised child” has changed. What seemed to be a strong program at the beginning of the decade may have become relatively weak, without people realising it.

#### Communication and Health Promotion

The national EPI recommends that every parent should receive basic health information before the administration of a vaccine to a child. With the first immunisation session an extensive health education session is required and a shorter session with each subsequent visit.

South Africa is a country with diverse communities and eleven official languages. Some communities have difficulty in accessing information and therefore rely on the health workers to provide the necessary information. Others are illiterate and cannot benefit from written information. Many people who can read do not understand English, the official language that we normally and frequently use for written information. We also have communities which are overwhelmed by the volumes of information that reach them either on doorstep, mailbox or electronically. These communities do not want more non-specific/targeted information.

The information on pamphlets about immunisation and the EPI diseases that is provided by the national EPI office should be seen as a guideline for use during health promotion talks. For example, the health worker uses the EPI pamphlets as a source of information, to develop a health education message appropriate to the target group. For other health workers and some members of the public, the information is too basic; they require more information or sources of information to consult.

#### **Important points to remember about Health Promotion:**

- The health education session should be short, with enough, but not too much information.
- Some parents do no benefit from a pamphlet and the vaccinator or health educator has to explain the contents during a discussion.
- A health promotion strategy should be adapted to provide for the specific needs of individuals and communities.
- For health promotion talks intended for groups, find out what the shared interest of the group members is.
- Establish what people already know about the topic before you start with health education.
- Be aware of the barriers in communication that may be present such as language and culture.
- At the end of the session always make sure the audience understands what you said.

## Essential information About Immunisation

The essential information that parents and women need when they come for immunisation include:

- The date and time of the next immunisation.
- The outstanding doses.
- The side-effects that may occur and how to manage these at home.
- Explain that the date is important to make sure the child completes the schedule on time.
- Give a written reminder of the date and time and if necessary, use reference points such as a community event to indicate the date.
- Entering the date of the next immunisation on the RTHC is recommended.

### **Side effects**

- Mild fever is normal for a day or two.
- Redness and swelling at the injection site for three or four days, do not put anything on it.
- If a small abscess develops at the injection site put a dry dressing on.
- Mild rash up to 7 days after measles immunisation is normal.
- The BCG papule heals by itself and the scar is normal, do not put anything on the papule and do not squeeze it.

Always invite parents and care givers to bring the child back if they are concerned.

## Risk benefit communication

The aim of risk-benefit communication is to ensure that information about vaccines and immunisation includes both the risks of the vaccine and the disease. Several studies worldwide have shown that the benefits of immunisation far outweigh the risks.

Mixed messages and incorrect information can undermine the immunisation programme. To assist district and facility health workers, the basic risk-benefit information about immunisation and vaccines should be made easily available, especially during vaccine scares and rumours.

## IMPORTANT INFORMATION ON RISK-BENEFIT COMMUNICATION:

- Research trials and measurements of efficacy made in the field have shown repeatedly that immunisation is one of the most effective medical interventions we have to prevent diseases.
- The current estimate is that immunisation saves over 3 million lives per year throughout the world, whilst remaining one of the most cost effective health interventions.
- Modern vaccines provide high levels of protection against several diseases, and protection against consequent disability and death.

- Serious adverse events following immunisation are rare. Despite a very good record of safety and effectiveness, there are people who have reservations about immunisation.
- Examination of the scientific evidence is important to assist health workers and parents in making an informed choice about the benefits and risks of immunisation.
- The benefits of immunisation should not be kept from any parent or child unless there is a scientifically demonstrated reason to do so.
- It is important that health workers are well informed about immunisation and be seen to be a good source of authoritative and scientifically justified advice. It is important that health workers openly discuss the benefits and risks of vaccination. Parents should also understand the benefits and risks of not vaccinating their children.
- Health workers should be positive about immunisation, as their attitudes have a major influence on patients.
- Opponents of immunisation are often vocal and make use of the media to express their opinion. This may be partly because most people accept immunisation and therefore anti-immunisation groups feel a need to express their opinion strongly.
- When a parent is unsure about immunisation and do not receive sufficient information from the health worker, this parent may be easily convinced by anti-immunisation lobbies with strong, apparently scientifically valid arguments against immunisation.
- Most arguments against immunisation appeal to parents' deepest concerns for the wellbeing of their children. It may not be easy for them to express the concerns to a health worker and anti-immunisation groups use this concern against immunisation. For such parents a positive and caring attitude is essential.
- Anti-immunisation arguments are based on a rejection of evidence supporting immunisation or are based on alternative views on health and health care. Because these arguments frequently appeal to emotional concerns about vaccines, it may be difficult to respond to them in a way that fully satisfies parents.

### **Development and implementation of activity plan for communication/social mobilisation**

At the beginning of each financial year, provinces and districts should prepare an integrated communication strategy plan for EPI (see appendix 8).

## MODULE 11: EVALUATING YOUR IMMUNISATION PROGRAMME

---

### SERVICE EVALUATION

Evaluation of your immunisation programme should be done weekly and monthly. This allows you to assess your success and assists in planning. We suggest a couple of simple methods but encourage every clinic to develop its own appropriate method of evaluation.

To aid evaluation, a Weekly "10 degrees" of Good Practice Chart is recommended.

**Week:** \_\_\_\_\_

**Date:** \_\_\_\_\_

**Were all planned immunisation sessions held?**

**Was there sufficient quantity of each vaccine to cover the period?**

**Was there sufficient, safe and sterile equipment?**

**Was the refrigerator temperature in the safe range (2-8°C) each day?**

**Was the immunisation status of all children who attended the clinic checked?**

**Were all opportunities taken to immunise all eligible sick and well children?**

**Were parents informed on remaining doses of vaccines and dates to return?**

**Were parents and their children turned away for any reason?**

**Was Immunisation data properly collected, summarised and double-checked after each Immunisation session.**

**Were concerns that parents or caregivers may have been properly addressed?**

If your answer to any of the above is "No" attempt to resolve the problem. If assistance is needed, contact your supervisor or district EPI co-coordinator.



## MONITORING VACCINATION COVERAGE

There are four steps in monitoring immunisation coverage. Accurate data is first collected; then aggregated; the aggregated data is analysed, interpreted and finally action is taken.

To help you to do this, there are simple forms to be completed.

1. **The Daily Primary Health Care (PHC) register:** After vaccinating a child or woman you should immediately record the immunisation doses given to each individual on the Immunisation register records (PHC Register). This helps to keep track of the Immunisation services offered to each infant and pregnant woman. Each dose given to every child or pregnant woman should be recorded against their names in the register. The immunisation doses must be totalled for each indicator at the bottom of each page, at the end of each immunisation session, end of each week and monthly. These should be double checked for errors before they are handed over as facility stats at the end of each month.
2. **The daily tally sheet:** Tally sheets: are the forms that health workers use to document an Immunisation session, by making a tick for every dose of vaccine given. Tally sheets should be used for all sessions whether fixed, outreach or conducted by mobile teams
  - a) Use a new tally sheet for each session
  - b) Give the dose first and then tally using the tally sheet.
  - c) Tally only the doses actually given; do not tally at the end of the session by counting vials used
  - d) Separate tally for under one and over one year of age, and pregnant women.
3. **Road to Health Booklet** should be filled accurately after vaccination of a child. It provides information to caregivers when to return for the next vaccination. It can be used for tracking defaulters and is very important in doing coverage surveys.
4. The **Monthly Summary PHC register: is a summary record of** all the daily data and total the number of immunisations given for each vaccine for the month. A copy of this monthly record should be sent to district supervisor at the end of each month.
5. **Immunisation Monitoring Chart** is a graphic tool used to monitor monthly coverage achievements for each vaccine against the set target population. The data from the monthly records are used to complete the graph and calculate dropout rates (See appendix 7).

## EPI DATA AND INFORMATION FLOW

The DHIS is the official national health information system that provides data for monitoring and evaluation of routine immunisation coverage. There is a standing national Data Flow Policy that relates to the DHIS. Over and above this policy, EPI-SA recommends the following for EPI data and information flow and management from facilities to higher levels:

- Data entry should be on the official provincial data collection forms.
- Facilities in the private sector that do not have access to the DHIS or a contact person to submit information to, may use the EPI tally sheet and monthly immunisation statistics forms. These facilities or service providers should contact the provincial EPI office to enquire where the information should be sent, request for the relevant data collection tools and for their service to be identified as a reporting unit and be included in the DHIS.
- Facilities and districts need to analyse their routine immunisation coverage data and should not wait for provincial or national feedback to evaluate their performance.
- Use the results to plan activities to improve the performance.

At the beginning of the year, each facility and each sub-district, district and province should prepare an *Immunisation Monitor Chart* for each immunisation indicator (Appendix 6). This should be filled in monthly.

In the Immunisation Monitor Chart there is a place for monthly targets. These should be obtained at the beginning of each year, normally available from the DHIS. Yearly target populations can be calculated using the following formula if not provided or not available:

$$\text{Monthly target for each vaccine} = \text{Total population served} \times 25/1000 \times 1/12$$

Keep this chart prominently displayed in the clinic. For an example, see appendix 9.

The Measles chart should be used to record the 9 month and 18 month doses given. For RV, the RV<sub>1</sub> and RV<sub>2</sub> doses are recorded. The DTaP-IPV//Hib monitor chart should record DTaP-IPV//Hib<sub>1</sub> and DTaP-IPV//Hib<sub>3</sub>, the Hep. B chart should record Hep. B<sub>1</sub> and Hep. B<sub>3</sub>

and similarly the PCV chart should be prepared to record PCV<sub>1</sub> and PCV<sub>3</sub>. The fully immunised chart can be used with PCV<sub>3</sub>.

At the end of each month transfer the total doses given for each vaccine from the monthly immunisation record to the monitor charts and calculate the cumulative totals. Plot the cumulative total coverage percentage with a dot on the chart and connect the dot to the previous month's dot with a line. You will be able to observe the progress towards achieving your targets. Compare the number of doses of each vaccine given each month and investigate reasons for any drop in activity.

You are encouraged to calculate the percentage of target children who received each vaccine, monthly. Begin with DTaP-IPV//Hib<sub>1</sub> and Measles until you find your feet.

$$\text{Percentage of target} = \frac{\text{Total number of children immunised with that vaccine in the month}}{\text{Monthly target}} \times 100$$

You should also at least calculate the *drop-out rate* for DTaP-IPV//Hib using the formula below. The drop-out rate for DTaP-IPV//Hib<sub>1</sub> to DTaP-IPV//Hib<sub>3</sub> is the percentage of children attending your clinic who receive DTaP-IPV//Hib<sub>1</sub> but not DTaP-IPV//Hib<sub>3</sub>.

$$\frac{\text{Number who received DTaP-IPV//Hib}_1 - \text{Number who received DTaP-IPV//Hib}_3}{\text{Number who received DTaP-IPV//Hib}_1} \times 100$$

If you find that the percentage of target children who received a particular vaccine is far above or below 90%, you may have a very poor estimate of your population or your service may not be effectively reaching all the children in the area. This should be tackled with the help of your supervisor.

If your clinic has high drop - out rates, you will have to design special ways of ensuring that children at your clinic return to receive all their vaccines.

## MODULE 12: SURVEILLANCE FOR EPI TARGETED DISEASE

---

### DEFINITION AND THE TYPES OF SURVEILLANCE

Surveillance is an ongoing systematic collection, analysis, interpretation, dissemination of health data and take appropriate action. Put simply, surveillance means watch or guard over a condition.

Surveillance is broadly classified into 2 groups: passive or active.

#### **Passive surveillance**

This refers to routine notifications and collection of information generated by the routine systems. This is the form of data collection in which health care providers and health workers send reports to a health department based on a known set of rules and regulations; in compliance with the Health Act – Conditions Notifiable By Law.

Under reporting and failure to report notifiable conditions is the major problem with this type of surveillance.

#### **Active surveillance**

This refers to a purposeful search for a condition. Some health workers are tasked with the responsibility of calling and visiting facilities to elicit reports and to check on facility records for the targeted conditions. Such facility visits should be conducted at frequent regular intervals. Active surveillance is usually limited to specific conditions. It is much more sensitive in picking up cases and gives a better indication of the actual incidence of the targeted condition.

#### **Sentinel surveillance**

This is a third form of surveillance, where a pre-arranged sample of reporting sites is chosen to report all cases of a selected condition. Usually the reporting sites are not selected randomly, are selected on their high probability of seeing the cases of the condition targeted for surveillance. The National Annual Ante Natal Care HIV survey is based on this form of surveillance.

## **Integrated Disease Surveillance (IDS)**

Integrated disease surveillance refers to integrating all surveillance activities common to all programmes (e.g. data collection, processing and dissemination, training, supervision and evaluation of surveillance programmes). Specific follow up actions are left to specific programmes.

Integrated disease surveillance aims to sum up all surveillance activities, which are conducted in a country and considers surveillance to be a common public service that carry out many functions using similar structures, processes and personnel. The various surveillance activities are integrated into one system within the broader national system.

Vertical surveillance systems that are linked to vertical programmes at provincial and national level may result in duplication of efforts and resources. Quite often these vertical programmes bear on the same health worker at sub-district and facility level. This leads to demotivation of health workers and inefficiencies in responding to real challenges facing surveillance and disease control. An example of vertical surveillance systems is that of surveillance for EPI conditions conducted independently of TB, malaria cases, meningitis and other conditions including cholera.

In integrated disease surveillance, when one conducts surveillance or search for EPI conditions, one will also look for malaria, meningitis, TB etc and vice versa. Similarly when training is conducted, training on all conditions under surveillance is done at same time.

**The guiding principles for integrated disease surveillance are that of: usefulness, simplicity & flexibility of the system, orientation to a specific action and integration.**

### **Uses of surveillance**

Surveillance has mainly two purposes: to monitor the health events and to determine & direct public health action/response. Surveillance should therefore be linked to public health action.

### **Monitoring the health events will:**

- Detect disease outbreaks.
- Draw long term trends and patterns of diseases.
- Identify changes in causative agents and host factors.

## Linking to public health action

Surveillance should form the basis for:

- Full epidemiological investigation of a case, e.g. investigation of a measles case.
- Planning of intervention measures, resource allocations etc.
- Setting of priorities.
- Evaluating programmes and intervention measures.
- Generating hypotheses and stimulating public health research.

## DISEASES FOR ELIMINATION AND ERADICATION

EPI-SA targeted 3 conditions for elimination or eradication. These conditions are:

- Poliomyelitis
- Measles
- Neonatal Tetanus.

**Elimination** refers to the interruption of transmission of a disease in a country or group of countries, but public health intervention measures including vaccination must continue.

**Eradication** refers to global interruption of transmission, leading to suspension of vaccination and major cost savings. The disease is made extinct (similar to small pox eradication).

The World Health Organization (WHO) developed strategies for elimination and eradication of these conditions. These strategies were tested in Western countries and other well developed nations, and proved to be effective in achieving elimination and eradication.

Strategies for Polio Eradication and Measles elimination are:

- High routine vaccination coverage of at least 90% by each district.
- Effective case based surveillance with active laboratory support.
- Mass immunisation campaigns.
- Mopping up immunisation activities in low and high risk areas.

Significant progress has been made in the eradication and elimination efforts, but much remains to be done for each of these 3 conditions.

## Measles elimination

South Africa had set a goal to eliminate measles, and interrupt the transmission of indigenous measles virus by end of 2002.

The measles elimination initiative started with a measles mass immunisation campaign for children 9 months to 14 years in 1996 and 1997 in South Africa. The first follow-up immunisation campaign, covering children 9 - 59 months of age, was conducted in 2000 and a second one in July 2004.

Up to September 2003, South Africa was considered to have virtually eliminated measles. The measles outbreaks in 2003/2004 and in 2009/2010 have dealt a major setback for measles elimination in South Africa. However, continued efforts on elimination strategies are expected to help ensure that South Africa regains the achievements in the control of measles.

WHO-AFRO has adopted a regional measles pre-elimination goal in 2008 and a number of targets to be achieved by 2012, including:

- >98% mortality reduction by 2012 as compared to estimates for 2000;
- Measles incidence <5 cases/million population per year at national level in all countries;
- >90% routine first dose measles vaccine(MCV1) coverage at national level, and >80% in all districts;
- >95% SIAs coverage in all districts;
- High quality Measles surveillance performance with:
  - Non-measles febrile rash illness rate of >2.0 cases per 100,000 population per year;
  - ≥1 suspected measles case investigated with blood specimens in at least 80% of districts per year; and
  - Routine district reporting from 100% of districts.

The two main performance indicators for measles surveillance are

- Non-measles febrile rash illness rate of >2.0 cases per 100,000 population per year;
- ≥1 suspected measles case investigated with blood specimens in at least 80% of districts per year.

## Case definition of a Suspected Measles Case (SMC)

Any patient who presents with fever and a maculopapular (blotchy) rash as well as with one of the following; cough, coryza (runny nose) or conjunctivitis

### How to investigate a Suspected Measles Case (SMC) case

- Detect a SMC using the case definition above.
- Fill in the appropriate Case Investigation Form.
- Collect blood specimen in a 5ml tube, and a throat swab using the appropriate viral transport medium available from hospital NHLS lab (Refer to Surveillance manual)
- Keep the specimen properly closed in specimen bottles in a fridge.
- Notify the infection control nurse and the district EPI or Communicable Disease Control co-coordinator immediately.
- Send the specimen to the laboratory (*specifically marked for National Institute for Communicable Diseases = NICD*).

We now need to:

- Strengthen measles case-based surveillance, by reporting every suspected measles case.
- Conduct prompt and complete investigation for every suspected measles case, including the collection of the laboratory specimens.
- Achieve and sustain 90% measles immunisation coverage in each district.
- Maintain the cold chain for measles vaccine.

## Polio Eradication

Polio eradication refers to complete absence of the condition in the whole world. When polio is eradicated the disease should never occur again.

Polio Eradication is a global initiative that was endorsed by the World Health Assembly in 1988. By end of 2002, 3 regions of the world had been certified free of wild poliovirus by the Global Certification Commission.

Certain strict criteria have to be met and sustained for 3 years before a country can claim to be free of wild poliovirus. Apart from high routine immunisation coverage and conducting mass immunisation campaigns, a high standard of Acute Flaccid Paralysis (AFP) surveillance needs to be achieved and maintained.



South Africa has not seen a case of wild poliovirus since 1989. This means that South Africa has been polio free for at least 21 years. In 2006 the Africa Region Certification Commission (ARCC) certified that South Africa had interrupted wild poliovirus transmission and thus declared South Africa free of wild poliovirus. However, there is still a need as also indicated by the ARCC, for the country to maintain the certification quality of AFP surveillance at provincial level and improve surveillance performance at district level, to be able to demonstrate that there are no cases of poliomyelitis due to wild poliovirus in South Africa.

Furthermore, AFP surveillance of high quality will enable detection of imported cases and facilitate the containment of spread if wild poliovirus was to be imported.

### **The case definition of Acute Flaccid Paralysis**

Any case of acute flaccid paralysis (sudden onset of floppy paralysis) including Guillain Barre' Syndrome, in a child less than 15 years of age not caused by trauma

### **AFP surveillance standard that all countries must reach.**

- Detect at least 2 case of AFP per 100 000 children below the age of 15 years.
- 80% of AFP cases must have 2 stool specimens, which are collected within 14 days of onset of paralysis. These 2 stool specimens must be 24 to 48 hours apart.
- The stool specimen must reach the National Institute for Communicable Diseases (NICD) within 3 days of collection, on ice.

We need to:

- Improve *disease* surveillance for cases of Acute Flaccid Paralysis (AFP), by reporting all AFP cases even if you are sure it is not polio.
- Promptly investigate all cases of AFP and specifically collect 2 stool specimens, 24 -48 hours apart, within 14 days of onset of paralysis.
- Achieve and sustain 90% immunisation *coverage* of DTaP-IPV//Hib 3 in each district.
- Give every new-born child *oral polio vaccine at birth*.
- Maintain the *cold chain* for polio vaccine.

## How to investigate an AFP case

- Fill in the appropriate Case Investigation Form, with all the necessary details.
- Collect 2 stool specimens of 5 -10 grams (a pinch with a spatula), 24 to 48 hrs apart, as soon as possible.
- Keep the properly closed specimen bottle in a fridge.
- Notify the infection control nurse and the district EPI or Communicable Disease Control co-coordinator immediately.
- Follow the provincial protocol on the transportation of stool specimens.
- Prepare to transport the stool in a cooler box on ice (reverse cold chain).
- Ensure collection of the second stool specimen, 24hrs after the first specimen.
- Notify the courier (once both stools have been collected), to collect the specimens.
- Ensure that the child is not discharged before the second stool specimen is collected.

## Neonatal Tetanus elimination

### Definition of Neonatal Tetanus (NNT) Elimination

Neonatal Tetanus Elimination refers to an incidence of NNT of less than 1 case per 1 000 live births in every district.

Tetanus spores are ubiquitous (found everywhere) in the environment; therefore Tetanus cannot be eradicated.

The elimination strategies for NNT elimination are:

- Immunisation of pregnant women with adequately spaced TT/Td doses.
- Improve maternity care and have a high proportion of clean deliveries attended to by a health care professional.
- Sensitive and effective surveillance and investigation for NNT cases.

### Progress made on NNT elimination in South Africa

South Africa had set a goal to eliminate NNT by 1997, that goal was not achieved. In 2000, South Africa set a goal to validate NNT elimination by end of 2002. This was achieved.

South Africa, with the technical expertise of WHO and UNICEF conducted in 2002 a Neonatal Tetanus Elimination Validation Exercise. The aim of the exercise was, “to find out if South Africa had eliminated NNT”. All the relevant data relating to: TT coverage for pregnant women, DPT 3 coverage, clean delivery coverage and traditional birth practices were reviewed. In addition two provinces (Eastern Cape and KwaZulu-Natal had field visits

to districts which were considered probably at risk of a high incidence of NNT; to establish the elimination status. The result of this exercise was that South Africa has eliminated Neonatal Tetanus.

Even though South Africa has eliminated NNT, there is a need to have a program in place, which will ensure that the elimination status is maintained. Failure to maintain the elimination status can result in an increase in NNT cases and loss of the Elimination status. To ensure maintenance of NNT elimination, the TT policy was revised, see schedule in module 3.

It is important to remember that:

**TT or Td can be safely given in the first, second and third trimester of pregnancy**

- 5 adequately spaced doses of Tetanus toxoid containing vaccines provide lifelong protection against tetanus.

**You have an important role to play! Help eliminate and eradicate; Measles, Neonatal Tetanus and Polio in South Africa**

- Use every contact with a child to check the immunisation status and provide immunisation if eligible.
- Report every case of measles, neonatal tetanus and AFP by the fastest means of communication to your district EPI/CDC Manager and actively participate in the investigation of the case.
- Participate in special immunisation campaigns, to ensure that all targeted children are reached.
- Use every opportunity to educate the community on the benefits of Immunisation, Measles Elimination and Polio Eradication Initiatives.
- Display posters with clear messages like:

**Immunise your child - Stop measles and other serious diseases.**

**Be healthy - Don't let measles get you**

**Polio can cripple and kill children**

**Immunisation of all children prevents deadly diseases**

Every facility and district must report monthly on the targeted diseases for active surveillance, i.e. the number of cases detected that month. Even if there were no cases reported that month, facilities should send in the monthly report to say there are no NNT cases, no measles cases and no AFP cases; having actively looked for these cases.

**This is Zero Reporting.**

## **EFFECTIVE EPI DISEASE CONTROL**

Recognising and reporting cases of EPI targeted diseases and other priority diseases is one of the most important tasks of a health worker. Health workers should know the symptoms of EPI targeted diseases under surveillance and be able to identify and report all suspected cases immediately by fastest means of communication to the District CDC/EPI co-coordinator. The district office will then investigate the case and report immediately to the Provincial EPI Manager and CDC manager.

The national Department of Health distributed a list of standardised case definitions for the EPI priority diseases. Standard case definitions are available in two forms: professional and lay case definitions.

**Standard case definitions** are designed for use by medical officers and nurses. These are primarily for hospitals, health centres and clinics where cases may present. All staff likely to see acute flaccid paralysis (AFP), neonatal tetanus (NNT) and measles cases, like staff in paediatric, out-patient or spinal unit wards, intensive care units, should know the case definitions and fulfil their obligation to report immediately.

It is important to understand that the case definitions are designed for disease control programmes and therefore may differ from what is found in medical textbooks. For disease control purposes, it is critical that every case of a disease is reported, even if this means that a few doubtful cases are included. This means the sensitivity for detecting these cases should be high.

The case definitions should be posted prominently in the examination rooms of hospitals, health centres and clinics for routine use when health workers see patients.

For various reasons, not all cases of EPI diseases are seen at hospitals, health centres and clinics. For example, worried parents sometimes bring AFP cases first to community-based rehabilitation centres, other facilities and to alternative care (traditional) practitioners. It is vital that these cases are not missed. The staff working in such facilities, and alternative health care practitioners should also participate in case detection and reporting, and should thus have the case definitions distributed to them.

In some situations many cases of EPI targeted diseases, especially NNT and measles, may never be brought to health facilities. In many societies, measles is not considered a serious disease. Similarly, many families accept illness and death with resignation and simply bury the body without seeking medical assistance. The detection of these cases poses a special challenge for disease control activities.

**Simple definitions for community participation:** Definition of the EPI diseases have been developed to ensure that cases may be readily recognised at the community level. The description of signs and symptoms should be made simple and clear, and should be translated into local languages, which are clearly understood by the community and widely disseminated.

All health workers from the public and private sector, community health workers, traditional birth attendants, traditional health practitioners, traditional and religious leaders, teachers and child minders should be trained to know the lay case definitions, and to report immediately to the nearest clinic / facility when they suspect a case has occurred.

For example, if local leaders or lay workers hear of a neonatal death or a child with sudden paralysis or measles in a village or township, the staff at the nearest health facility should be notified immediately. These local leaders in the community should then lead the health facility staff directly to the home where this occurred to collect basic details. The district health staff is then alerted to carry out a prompt case investigation.

Village and township meetings should be held and the benefits of detecting and responding to such cases in the community explained in clear terms to community members. A **reporting chain** from local leaders and lay workers to the authorities / facilities for case investigation and response must be defined.

It is important that a monthly summary report of cases is submitted within the given deadline, even if none of the targeted diseases have been detected, “**zero reporting**”.

## MODULE 13: REACH EVERY DISTRICT (RED) STRATEGY

---

### BACKGROUND

In the National Health Strategic Plan 2010/11 to 2012/2013, South Africa, set the goal of 95% coverage for the fully immunised child under 1 year by the end of 2013, with every province achieving at least 80% coverage. Significant progress has been achieved and the current coverage for fully immunised, the 3 primary doses (DTaP-IPV//Hib<sub>3</sub>, Hepatitis B<sub>3</sub>) and measles<sup>1</sup> are above 90% at national level. However out of the 52 districts 16 (30.8%) and 11 (21.2) did not reach the target of 80% for fully immunized children in 2010 and 2011 respectively.

Aggregated provincial and national coverage figures are misleading and quite often mask huge variations at district and sub district level. For the immunisation programme to win the war against childhood vaccine preventable diseases and outbreaks, high immunisation coverage levels should be achieved at district and sub district level.

The Reach Every District (RED) Strategy focuses at district and community level with the primary aim of improving the organization and management of immunisation services so as to guarantee sustainable and equitable immunisation services that will reach every child.

The RED strategy is not a new intervention, nor does it replace the existing programmes and interventions, but rather it aims to strengthen the routine Immunisation programme. It emphasises on strategies that when utilised appropriately will strengthen the systems for Immunisation services and the entire health system for the delivery of primary health care services.

The implementation of the RED strategy is recommended to maximize the use of available resources and ensure that the immunisation programme achieves a high level of immunisation coverage that will be sustainable. RED strategy should support the disease elimination and eradication efforts.

*The most recent focus is on **Reaching Every Community** in order to reach every child. Therefore RED Strategy may soon be rephrased to REC Strategy.*

## **Operational components of the RED strategy**

The RED strategy has 5 operational components, which are based on common barriers to achieving immunisation goals.

### **Components of the RED strategy**

- ❖ Planning and Management of Resources
- ❖ Reaching target populations and Providing Outreach Services where necessary
- ❖ Links between community and the service
- ❖ Supportive Supervision
- ❖ Monitoring for Action

## **IMPLEMENTING THE RED STRATEGY**

The RED strategy uses the district as a focus for assessment, problem solving, budgeting and implementation.

At national and provincial level, the number of unimmunised children per district helps to determine which district should be prioritised for implementation of the strategy. Within a district, sub districts or local service areas with low immunisation coverage should be prioritised for RED strategy implementation, paying particular attention to the sub districts with large populations, which have large number of unimmunised children. Implementation should follow and be based on the operational components.

### **(i) Planning and Management of Resources (human, material and financial)**

This is the most basic component of the RED strategy. All the other elements of the RED strategy cannot be implemented if the planning process has not been conducted properly. The implementation of the strategy should then follow closely on the objectives and activities as laid out in the plan.

At the district and facility levels, planning should identify what resources are needed to reach all those targeted, in a way that can be managed well and thus maintained. Good planning involves: (a) understanding the district/health facility catchment area (situational analysis); (b) prioritising problems and designing micro-plans that address key gaps; (c)

developing a budget that realistically reflects the human, material and financial resources available; and (d) regularly revising, updating and costing micro-plans to address changing needs.

***“If You Fail to Plan, You Plan to Fail!”***

Planning should be systematic and have a problem solving approach: analysing the situation of achievements and barriers; available human, material and financial resources; prioritising; setting realistic targets with milestones, including sustainability issues and regular reviews of implementation and achievements to facilitate timely revision.

The planning process helps to expose all the problems associated with EPI and to develop appropriate strategies for resolving them. A good formulated EPI plan should propose solutions to the following critical issues, which all programme managers are confronted with at district level:

- How to increase immunisation coverage and reach every child?
- How to maintain the quality of immunisation services?
- What can be done to reduce dropout rates and missed opportunities?
- How to improve the quality of Immunisation coverage data?
- How to ensure effective supervision?

A district plan should take into consideration the situation in the different service areas and different health facility performance. The district / sub-district should conduct the planning session with representatives from health facilities.

It is advisable that in addition to the health facility, chiefs, community leaders (Clinic Health Committee members), regional health plus provincial health representatives and development partners are involved in the planning process.

**Steps in the Process:**

- Familiarise participants with the RED strategy and its implementation.
- Micro-planning should be by each health facility with support from District Health Management Team (DHMT), on specific areas like “How to increase immunisation coverage.”
- Aggregate health zone plans into a district level plan showing identified needs, budget estimates, implementation schedule and how they will be managed.



- The DHMT should also address specific areas related to this level including: supervision, transport, equipment (fridges, cooler boxes, scales etc), supplies of vaccines and other essential consumables ongoing training and mentoring.

Good planning involves:

- Understanding the district/health facility catchment area (situational analysis);
- Prioritizing problems and designing micro-plans that address key gaps;
- Developing a budget that realistically reflects the human, material and financial resources available; and
- Regularly revising, updating and costing micro-plans to address changing needs.

### **Situation analysis**

As part of micro-planning it is important to conduct a situation analysis and set targets for the year. Analyse the 2-3 years data on vaccination coverage for all vaccines provided by dose and dropout rates. This should be done by health facility and by sub district. Establish if there has been any satisfactory increase in coverage and if the dropout rates are below 10%.

The situation analysis should address the following questions, reviewing a 1-year period:

- Were the service delivery strategies working? If not why?
- Were there any identified barriers to access or to utilisation of services?
- Were vaccines, syringes, needles and other supplies available in adequate quantities throughout the period?
- Was cold chain equipment adequate, for all service delivery strategies and functional?
- Were human resources adequate and trained to conduct and monitor the services?
- Was transport available and reliable for distribution, outreach and supervision?
- Did each health facility monitor coverage and dropout rate?
- Did each health facility conduct monthly review meetings to discuss progress?

The problems should then be prioritised.

## Managing the resources

### ***Immunisation is the most cost-effective public health intervention***

The assumption of this statement is that all resources; human, material and financial are used and managed in an efficient manner

To manage resources efficiently, it is important to:

- Plan and deploy resources according to situational analysis, objectives and most appropriate strategies taking into account the needs and availability.
- Know and declare resources made available by all stakeholders. Include locally (Local Authority and Community) mobilised resources, both cash and other forms.
- Identify gaps and utilise existing coordination mechanisms at district level to raise funds and monitor implementation.
- Pool resources and utilise all integration opportunities e.g. transport for distribution shared with other programmes, minimum package for outreach (include, nutrition – Vitamin A, malaria needs – bed nets etc).
- Plan together activities which involve the same person/same facility to avoid duplication.
- Distribute resources on the basis of equity (needs) and not equally.
- Conduct regular maintenance of equipment (cold chain/transport).
- Update inventory of equipment annually – include models, working status, repair history and spare parts).
- Account for the resources at disposal.

## Operational considerations for implementation

### Logistics

The implementation of the operational components of the RED strategy cannot be achieved without proper logistics support. It is crucial to get the logistics right in order to start implementing the RED strategy effectively.

All immunisation operations; like service delivery in fixed and mobile sessions, supervision, communication etc.) depend on effective and efficient logistics which includes:

- Vehicle management.
- Injection material management.

- Cold chain management.
- Transport management.
- Safe disposal of waste.
- Maintenance of all major equipment.

Logistics activities at district level are outlined below:

- Logistics data should be included in the district map.
- Ensure availability of vaccines, injection materials and other supplies.
- Ensure cold chain management.
- Ensure availability and reliability of transport.
- Ensure safe waste disposal and destruction.
- Ensure proper equipment maintenance.

## **(ii) Reaching the Target Population and R-establishing Outreach Services**

In implementing the RED strategy, the aim should be to ensure Sustainable Outreach Services that will *Reach Every Child*.

Regular outreach to underserved communities is an essential strategy for routine immunisation services. Successful outreach services can only be conducted from a fully operational health facility, equipped with a functional “vaccines-only” refrigerator, with enough supplies of potent vaccines and injection equipment, manned with adequately trained, paid and supervised health workers with functional means of transportation for outreach services.

It is important to conduct a situation analysis before one can plan for outreach services. One has to establish, the number of facilities within an area of focus (district or sub district), establish where these facilities are located, which ones render outreach services, which populations are underserved, the reasons for being underserved and what it will take to reach these populations.

### **Service area for a health facility:**

- Obtain and draw a map of the district/sub district.
- Map out the location of all facilities and their special target population by villages they serve. Include schools and other community resources.

- Assign each facility an area of responsibility/service area and provide the facility with the map of the area or help draw up a map.
- Adjust the limit of the service areas according to the natural demarcation.

### **Strategy**

- Support each facility to determine how they will serve the targeted underserved population.
- Determine the population of the targeted communities and decide which type of strategy will best serve each community targeted.
- Determine the number of sessions per month for each community.
- Consider integration with other programmes available in the area, eg. Malaria control, Nutrition, IMCI, etc.
- Discuss the schedule and location of service points with communities through local authorities and opinion leaders to reach consensus and involvement of the community to make sessions effective.

### **Delivery of service**

Ensure that health facilities are operational: functional fridge available, available vaccines and injection equipment, transport for outreach, trained and supervised health workers.

Support health facilities to use a checklist to prepare for an outreach.

Provide adequate information to the health worker in charge of the outreach. This should include; immunisation points, number of visits needed and information on how to respond to adverse events following immunisation (AEFI).

Track targeted children and women by keeping registers and updating them monthly.

Follow up on defaulters using an appropriate system.

### **(iii) Supportive supervision**

Supportive supervision promotes quality outcomes by strengthening communication, focusing on problem solving, facilitating teamwork, providing leadership and support to empower health workers to monitor and improve their own performance.

It is important to:

- Plan to conduct regular supervisory visits; monthly and quarterly.
- Arrange more visits for poor performing facilities.

- Incorporate supervision in district micro-plans and budget for it.
- Ensure effective supervisory visit that identify and address challenges in facilities.
- Ensure that problems identified during supervisory visits are addressed.

Refer to the Supervision module for more details on supervision.

#### **(iv) Linking Services with Communities**

Health services cannot be optimally effective if the communities for which the services are intended are not meaningfully involved in the structuring and management of the service. Strengthening the link between the community and the service will help create awareness, stimulate demand, help convince those that are hard to reach and encourage community participation.

This will allow effective empowerment of the community, which should result in a sense of ownership of the services offered.

Well-planned communication activities for the district are important to:

- Generate support for immunisation from political leaders and decision makers,
- Improve quality of immunisation services through interaction between health workers and clients, continuous public information, update, feedback, and timely response to adverse events and rumours,
- Help reach the hard to reach,
- Enhance community ownership.

#### **Clinic Health Committees (CHC)**

Re-establish and/or ensure that the Clinic Health Committees (CHC) are functioning. These committees should meet regularly and address key matters on service delivery. The community should be well represented in the CHC preferably with the key opinion leaders (e.g. religious and community leaders).

The CHC will facilitate and enhance the effectiveness of most of the activities listed below. Key activities to link the services with the community include the following:

- Involve the community in planning and monitoring of the immunisation services.
- Use existing community structures for communication.

- Mobilise and organise groups such as the scouts, school children and teachers and other volunteers and assign them specific roles e.g. defaulter tracking.
- Hold regular meetings and share progress, coverage figures or utilisation figures, problems and impact of immunisation with the appropriate groups as feedback.
- Disseminate information on a regular basis to the community through the meetings, local radio, and other appropriate channels.
- Conduct training for health workers and community educators to strengthen their interpersonal communication skills.
- Supervise communication activities to ensure proper information is given; this can also be part of supervision.
- Conduct exit interviews, and focus group discussions with community members to understand their needs and expectations. Use the feedback to improve service delivery.

#### **(v) Monitoring for Action**

Monitoring for action entails a systematic and continuous process of examining data, procedures and practices linked to implementation of programme activities. The information is used to direct the programme in planning, measuring progress, identifying areas needing specific interventions and revision of plans if needed.

#### **Monitoring for action requires:**

- A functioning health information system that provides data, that is reliable and timely.
- Adequate resources – human, material and financial.
- Regular analysis and review of collected data.
- Feed-forward and feedback of information according to established deadlines.

Getting quality data:

- Establish the best estimates of the target population for the district, sub-district, village and facility.
- Ensure adequate registers & books are available for data capture.
- Keep checklists to check reports submitted and remind facilities not submitting data by agreed deadline.
- Keep back up files (or copies) at each level (facility, sub-district) for verification when needed.
- Investigate cases and outbreaks of vaccine preventable diseases (measles).

### **Using generated data:**

- Ensure that each facility has a wall chart for monitoring coverage.
- Should denominator figures not be available to allow calculation of coverage, the doses for the antigens should be display (e.g. doses of DPT-Hib3 and measles given by month)?
- Generated data should be analysed.
  - Determine vaccination coverage and dropout rates for every month.
  - Determine vaccine wastage at facility and district level.
  - Establish the cases and deaths of vaccine preventable diseases by age and vaccination status.
  - Do line listing of all investigated EPI diseases.
- Conduct monthly and quarterly reviews of analysed data and compare trends of vaccination coverage with disease incidence.
- Follow trend of vaccination in each facility by charting monthly coverage.
- Use Maps, graphs and charts to illustrate vaccination coverage or immunisation doses and dropout rates by health facility and its catchment area.
- Use dotted map to indicate cases and deaths.

The RED Strategy and approach should be used at all levels to increase immunisation coverage and the principles should be applied to all programmes to improve health service delivery.

## MODULE 14: SUPERVISION AT FACILITY LEVEL

---

### BACKGROUND

This section provides guidelines for EPI supervision at a facility level. The clinic supervisor will conduct supervision for other services/programmes provided by the clinic, thus there is overlap with the general supervision that the clinic supervisor will be conducting.

A clear **supervisory policy**, governing all the elements of the supervisory process is vital to enable the development of good quality supervision. It is expected that each province will be having its own policy that will amongst other areas cover the following: describe the structure of the clinic supervisory system, define the regularity of the supervisory visits, define the responsibility of the provincial and district authorities to ensure effective supervisory practices and define the components of a supervisory visit.

At the district level, supervision should be specifically **planned and budgeted** for. It is important to incorporate supervision in the district micro-plans and budget. The district office has a responsibility to train the clinic supervisor, provide transport for the supervisor to conduct the supervisory visits, allow her/him time to conduct the supervision and give the supervisor the necessary authority (written – letter of authority) to enable the supervisor to access needed resources (e.g. plumbers, electricians, other health administrators etc.) and address challenges.

This module assumes that regular facility supervision will be conducted monthly and an in depth program review conducted quarterly.

### BASIC PRINCIPLES OF SUPERVISION

Supervision is the process of making people improve their own performance. The ultimate aim of supervision for EPI is to improve the quality of immunisation services and improve immunisation coverage.

Supervision is different from inspection, in that the supervisor supports the health workers being supervised. The emphasis is “*Helping to make it work.*” Rather than “*Finding what is wrong.*”



Supervision involves periodic visits to the facilities. Poor performing facilities should have more visits.

For supervision to work, supervision needs to:

- Be planned.
- Be timely and regular.
- Provide onsite training.
- Keep promises/Follow up on promises made during the visits to address challenges.

### **Why conduct supervision?**

Health Care workers face many problems, especially those in remote settings. Supervision can help with the following;

- Provide technical advice.
- Help health workers plan, implement and evaluate their work.
- Provide continuing education.
- Handle grievances.
- Provide good leadership.
- Motivate health care workers.
- Ensure the facility's objectives are appropriate.
- Find out what is being done well.
- Reinforce good practices.
- Help identify and solve problems.
- Identify training needs.

## **ORGANISING THE WORK OF A SUPERVISOR**

### **Administrative session**

- Open a **file for each individual clinic**. In this file all the administrative records are kept e.g. policies provided to the clinics, requests for repairs, important notes following previous visits and other matters which need documentation.
- Keep a **supervisor's list of all the contacts**. This will enable you to deal promptly with the important issues, without having to follow complicated bureaucratic lines of communication. This list will be completed with participation of the district manager, showing various officials and institutions from which you may seek help in carrying out

your supervisory responsibilities, (with the appropriate authority having been granted to the supervisor).

- **Schedule the visits.** A clinic supervision schedule will allow the supervisor to schedule clinic visits one year in advance. Record the dates on which you expect to visit the clinics for which you are responsible.
- Keep a **monthly report** of all the facilities supervised and which areas were supervised e.g. indicate if the In-Depth programme review was conducted.
- Keep a follow up activity list that highlights the main activities needed for each clinic under your care, with the due dates for such activities.
- **Monitor the performance of the facilities.** This is done by comparing the performance of facilities under your responsibility. You may graph the immunisation coverage of the different clinics or the number of vaccine stock outs each clinic has experienced over a 3 - 6 month period.

### **Planning the content of a supervisory visit**

It is not possible to supervise all aspects of the programme on every supervisory visit.

The supervisor needs to classify the areas to supervise into the following recommended categories:

- Red Flag = the critical elements which can bring a service to a halt.
- Regular review = the elements that have to be checked on all visits.
- In depth programme review = detailed assessment of the programme conducted quarterly.

In addition there will be the following areas, which the supervisor will decide when to cover:

- Training sessions.
- Problem solving plus discussions.
- The review of actions and expectations.

The supervisor will plan training sessions for the facility staff and conduct training to update staff on new policies and new practices as desirable. The supervisor may choose to conduct these quarterly when the in depth reviews are conducted.

Similarly, the problem solving discussions and review of expectations will be held from time to time as deemed suitable. Please note that, other problems cannot wait for the scheduled sessions, in which case a discussion should be conducted on the spot as the need may arise.

**The Red Flag and the regular review lists should be covered on all supervisory visits**

**Red Flag Section (see – Red flag list in the next page)**

The Red Flag list allows for a rapid review of the key elements of critical importance for service delivery. The absence of any of the elements implies that the immunisation programme cannot deliver the services, and thus needs to be urgently rectified.

The list is completed by rapidly checking on the few critical elements with a YES or a NO. A space is provided to note the actions taken and further actions required to deal with key problems and ensure that the problems do not keep on recurring.

**The Regular Review (see regular review list)**

The Regular Review list enables regular monthly review of the important elements in immunisation service delivery.

Most of this section is completed with a Yes or a No, the action to be taken and who will be responsible – either the clinic or the supervisor.

The other areas look at checking on the Road to Health Cards (RTHC) or booklets, and the checking on the availability and use of the health information.

**In Depth Program Review (see quarterly review list)**

In-Depth Program Review is conducted at quarterly intervals allowing for a much more thorough assessment of the programme. It should be well planned and may very well be conducted with; training, problem solving and review of actions and expectations. Proper recording of the findings and the issues to be followed up is crucial.

The In-Depth Program Review should be used to assess the training needs of the staff and to decide on the training topics and material for the next training sessions.

On the supervisory form, sample attached, make notes on issues to be followed up and any other comments on the facility visit.

## EPI Red Flag Checklist

**Date:**

<b>Clinic</b>		<b>Supervisor</b>	
<b>District</b>		<b>Facility Manager</b>	

<b>Critical element</b>	<b>Yes</b>	<b>No</b>	<b>Emergency actions and comments</b>
2 ml Syringe Stock Out			
22/23 gauge Needle Stock Out			
Vaccine stock Outs			
Refrigerator Functioning			
Mobile services Functioning			
Break down of Mobile service vehicles			
Staff Available to conduct mobile services			

<b>Item</b>	<b>Immediate actions</b>	<b>Long term actions</b>

## Regular Review Checklist

**Date:**

<b>Facility</b>		<b>Supervisor</b>	
<b>District</b>		<b>Facility Manager</b>	

### Supervision Elements

<b>1. Immunisation sessions</b>	<b>Y</b>	<b>N</b>	<b>Action to be taken</b>	<b>Sup</b>	<b>Clin</b>
Is Every Day an Immunisation Day					
* Were all scheduled mobile sessions held					
* Were clients turned away					
*Breakdown of mobile vehicles					

\*These questions relate to the period since the last supervisory visit / since the last month.

<b>2. Vaccine management</b>	<b>Y</b>	<b>N</b>	<b>Action to be taken</b>	<b>Sup</b>	<b>Clin</b>
Stock card kept					
Stock card correctly filled					
Been out of stock in last 3 – 6 months					
Are there expired drugs					
Are there VVMs past discard point					
Is vaccine wastage managed/monitored					
Is there overstocking of vaccines? e.g. Td, OPV, measles.					

<b>3. Cold Chain</b>	<b>Y</b>	<b>N</b>	<b>Action to be taken</b>	<b>Sup</b>	<b>Clin</b>
Fridge Temp chart					
Temp chart properly 2x day and recently filled					

Fridge Temp in correct range					
Fridge correctly packed					
Are there dial thermometers in fridge and cooler box.					
Adequate cooler boxes					
Diluent cooled					
Ice packs reconditioned					
Is there a contingency plan for power failure?					

<b>4. Clinical Practice</b>	<b>Y</b>	<b>N</b>	<b>Action to be taken</b>	<b>Sup</b>	<b>Clin</b>
Is there triage of clients whilst in queue					
Is reconstitution proper					
Are reconstituted vaccines fully labelled					
Are needles/syringes left on vials					
Are injection sites correct					
Are vaccines frozen					
Are there reconstituted measles vials in the fridge?					

<b>5. Information</b>	<b>Y</b>	<b>N</b>	<b>Action to be taken</b>	<b>Sup</b>	<b>Clin</b>
Are the given doses correctly ticked on the Tick Register, Tally & Immunisation Register <b>OBSERVE</b>					
Is Immunisation data summarized daily/per session; per page and weekly: <b>D Check figures</b>					
Are there data discrepancies. <b>Check the Monthly summary</b>					
Is Fully Immunised always equal Measles 1; even with stock outs?					

Is there an Immun. Coverage Monitoring chart					
Is data verified before it is sent to next level. Verify this with discrepancies etc.					
Is the Road to Health card properly filled?					

<b>6. Social Mob &amp; Communication</b>	<b>Y</b>	<b>N</b>	<b>Action to be taken</b>	<b>Sup</b>	<b>Clin</b>
Are there planned Health Promotion Sessions					
Is EPI included in these sessions					
Are there Clinic Health Committees					
Do these meet regularly					

<b>7. EPI Disease Surveillance</b>	<b>Y</b>	<b>N</b>	<b>Action to be taken</b>	<b>Sup</b>	<b>Clin</b>
Is the Facility Manager aware of surveillance for EPI conditions					
Has the facility detected any of the conditions in the last 1 to 2 years?					
Do the Health Workers know which specimen to collect for AFP & Measles?					
Are there CIF for all 4 conditions*					

CHC= Clinic Health Committees, CIF= Case Investigation Forms, 4 conditions = measles, AFP, NNT & AEFI

### 8. Collect 5 RTHC/ Booklets and see if they are correctly filled

Number of RTHC correctly filled

Total number of RTHC checked

### Notes

## Quarterly Review Checklist: In Depth Program Review

CLINIC

DATE

[✓] Tick appropriate box

	Yes	No
<b>1. Service Delivery</b>		
<input type="checkbox"/> Is the immunisation service available daily, 5 days a week		
<input type="checkbox"/> Is there a system to ensure continuity of care		
<input type="checkbox"/> Do staff trace children who do not come for their routine immunisations		
<input type="checkbox"/> Are posters on immunisation on the walls		
<input type="checkbox"/> Are these posters in the local language		
<input type="checkbox"/> Are pamphlets on immunisation		
<input type="checkbox"/> Are these pamphlets available in the local language		
<input type="checkbox"/> Is the district/provincial telephone number displayed, so that notification of a suspected case can be made telephonically		
<input type="checkbox"/> In cases of measles and Acute Flaccid Paralysis (AFP) do staff know which laboratory specimens to collect		
<input type="checkbox"/> Do they follow referral procedures		
<input type="checkbox"/> Vaccine stock: <ul style="list-style-type: none"> <li>• Are stock cards kept for each vaccine</li> <li>• Do stock card levels correlate with the stock in refrigerator</li> <li>• Are vaccines received regularly and according to amounts ordered</li> <li>• Is the cold chain maintained when vaccines are removed from refrigerator</li> <li>• Have you had to turn clients back at this facility since the last supervisory visit</li> <li>• If yes for how many days</li> <li>• What was the cause for turning clients back</li> </ul> How was the problem solved		
	Yes	No
<b>2. Refrigerator</b>		
<input type="checkbox"/> Is the refrigerator in working order		
<input type="checkbox"/> How many times since the last supervisory visit has it failed		
<input type="checkbox"/> What did you do to maintain the cold chain		
<input type="checkbox"/> Is the refrigerator a dedicated vaccine fridge		
<input type="checkbox"/> Is the cold chain maintained during defrosting		
<input type="checkbox"/> Are vaccines correctly stored and packed in refrigerator		
<input type="checkbox"/> Are there any expired vaccines		
<input type="checkbox"/> Are there VVMs past the discard point		
<input type="checkbox"/> Is the thermometer/fridge-tag in working order		
<input type="checkbox"/> Is the thermometer/fridge-tag correctly placed		
<input type="checkbox"/> In the last month, has the temperature dropped below 2°C or above 8°C. If yes discuss the reason for this break in cold chain and remedial action to be taken by staff.		
<input type="checkbox"/> Is there anything else in the refrigerator besides vaccines		
<input type="checkbox"/> Is there a standby gas supply if the refrigerator uses gas		
<input type="checkbox"/> Have any of the "Do not Freeze" vaccines in the refrigerator been frozen.		
	Yes	No
<b>3. The Cold Chain maintained in mobiles and consulting rooms?</b>		



• Large cold boxes available and in working order		
• Small cold boxes available and in working order		
• Ice packs available		
<b>4. Is the multi dose open vial policy followed</b>	<b>Yes</b>	<b>No</b>
• Date of opening recorded and time for measles		
• Reconstituted vials of measles from previous sessions in the fridge		
<b>5. RTH card check</b>	<b>Yes</b>	<b>No</b>
• Are vaccinations appropriate for age		
• Are given doses entered correctly		
• Are signatures and return dates entered		
<b>6. Vaccination technique</b>	<b>Yes</b>	<b>No</b>
• Are vaccines reconstituted correctly		
• Are the correct needles and syringes used		
• Is the injection site correct		
<b>7. Information given to caregiver</b>	<b>Yes</b>	<b>No</b>
• Is the return date indicated		
• Is the caregiver aware of side effects		
<b>8. Emergency tray</b>	<b>Yes</b>	<b>No</b>
• Is the emergency tray properly equipped		
• Is the nurse aware of the emergency procedure		
<b>9. Recording of EPI data and monitoring performance</b>	<b>Yes</b>	<b>No</b>
• Are EPI statistics and graphs kept up to date		
• Is the tick register completed properly		
• Is the coverage/graph correct and up to date		
• Are vaccine batch numbers recorded		
<b>10. Severe adverse reactions</b>	<b>Yes</b>	<b>No</b>
Since the last supervisory visit have you had any reports of reactions, such as injection site abscesses sever local reaction spreading further than 5 cm from injection site; or anaphylaxis, convulsions, hi High fever) after immunisation		
<b>11. Notification</b>	<b>Yes</b>	<b>No</b>
• Is the notification book available		
• Is the list of notifiable diseases available		
• Are case investigation forms available		
<b>12. Is there need for in-service on EPI</b>	<b>Yes</b>	<b>No</b>
<b>13. Are sharps disposal adequate?</b>	<b>Yes</b>	<b>No</b>
<b>14. Is sharps disposal less than ¾ full?</b>	<b>Yes</b>	<b>No</b>





## APPENDIXES

### Appendix 1: Characteristics and Important Points About EPI Vaccines

Name of vaccine	Type of vaccine	Issues to consider about the potency of the vaccine	Side effects of the vaccines	Things to remember and information for parents
BCG	Live weakened bacteria vaccine Freeze dried	Loses potency within 6 hours after reconstitution Easily damaged by sunlight and heat	Local reactions such as redness, swelling and mild swelling of surrounding lymph nodes	Inform parents about the formulation of a normal papule and not to put anything on the papule
DTP-change to DTaP-IPV//Hib	Diphtheria and Tetanus vaccines are toxoids Pertussis vaccine is a killed bacteria	Freezing damages all components of the vaccine	Fever for up to 24 hours after injection Pain and local swelling at the injection site for 1-2 days	If a child had convulsions or other severe reactions to a previous dose, another pertussis dose should NOT be given and noted on the RTHC
OPV	Live weakened virus vaccine	Easily damaged by heat Each vial has a Vaccine Vial Monitor (VVM) to indicate the potency of the vaccine	No mild side-effects	A child can be fed /breastfed before or after immunisation. Children with diarrhoea should receive a dose . If a child spits or vomits, give another dose immediately
Measles	Live weakened virus vaccine Freeze dried	Loses potency within 6 hours after reconstitution Easily damaged by sunlight, heat, disinfectants and alcohol	Some children may have fever, accompanied by a mild rash for up to 72 hours after immunisation	Inform parents about the possible mild rash and fever and not to be concerned
Hepatitis B	A plasma-derived or DNA recombinant vaccine	Freezing damages all components	Fever for up to 24 hours after injection Pain and local swelling at the injection site for 1-2 days	Inform parents about the management of mild fever and not to put anything on the injection site
Hib	A conjugate vaccine Freeze dried or liquid	Freezing damages Hib vaccine	Fever for up to 24 hours after injection Pain and local swelling at the injection site for 1-2 days	Inform parents about the management of mild fever and not to apply anything on the injection site
Rota virus	Live attenuated viral vaccine Clear liquid suspension	Do not freeze (keep in 2°C to 8°C, protect from light	Diarrhoea, irritability, rarely flatulence and abdominal pain	Advise parents to come back if severity of abdominal pain (inconsolable crying) persists

Pneumococcal vaccine	Conjugated polysaccharide vaccine	2°C and +8°C, do not freeze; discard if frozen	Fever, injection site redness and swelling	Inform parents about the management of mild fever and not to put anything on the injection site
DTaP-IPV//Hib	Combined vaccine – toxoid of diphtheria and tetanus, acellular pertussis, Inactivated polio and conjugated capsular polysaccharide Hib vaccines	2°C and +8°C DO NOT FREEZE. Discard the vaccine if it has been frozen.	Redness, induration at the injection site, fever $\geq 38^{\circ}\text{C}$ . rarely the fever can go higher	Inform parents about the management of mild fever and not to put anything on the injection site; bring the child back if fever or symptoms get worse









Appendix 5 : Fridge-tag Temperature Chart

Fridge-tag <sup>®</sup> recording sheet										
District				Health Facility				Refrigerator No.		
Month/Year										
Equipment										
Day	AM	PM	▲ °C	Alarm/OK	Duration	Initials	▼ °C	Alarm/OK	Duration	Initials
1										
2										
3										
4										
5										
6										
7										
8										
9										

## Appendix 6 : Fridge-tag User Manual

### How to Activate the Fridge-tag

You receive the device in “**sleep mode**”. The LCD screen is blank. To activate the device press the **SET** and the **READ** buttons simultaneously for more than 2 seconds. Four zeros will appear on the screen. The first zero will flash.



### Setting the Time

Use the **READ** button to adjust the time. Each time you press the **READ** button, the number in the flashing digit will increase by 1. For example, if you want to set time to 13:47 you have to perform the following steps:

1. The first digit is flashing: Press **READ** once. “1” will appear as the first digit. Press **SET** to save.
2. The second digit will start flashing. Press **READ** three times, when “3” appears as the second digit press **SET** to save.
3. The third digit will start flashing. Press **READ** four times to set the digit as “4”. Press **SET** to save.
4. The last digit will start flashing; Press **READ** seven times to obtain “7”. Press **SET** to save.

If you press **READ** more than necessary continue pressing the **READ** button until you obtain the desired number, then press **SET** button to save your Settings.

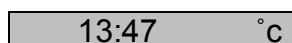

### Setting the temperature measurement unit

After finishing the time setting, the “°C” sign will appear at the right bottom corner. If you would like to record and read temperatures in Centigrade, press **SET**. Therefore, the activation is completed and on the display the word “**Loc**” appears. For a period of 10 minutes, the Fridge-tag does not measure the temperature to avoid false readings. This allows an adaption to the environmental temperature before normal reading continues. If you want to record in Fahrenheit, press **READ** once and the “°F” sign will appear, then press **SET** to complete the activation. Once the device is fully activated, the “**OK**” sign and **current temperature reading** will appear on the screen.

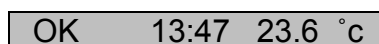

### Changing the time setting

If you made a mistake or wish to change the time setting, it can be readjusted. The number of possible time adjustments during a day is unlimited. But after any time adjustment and the next midnight date shift, the adjustment mode is locked for 24 hours following the midnight date shift. This is for security reasons. Thus, a new setting is possible only after the 2<sup>nd</sup> date shift again.

To adjust the time after device has been activated, you need to press and hold the **SET** button and press the **READ** button shortly. Then you need to repeat the steps as described in “Setting the time”. Additional time adjustments have no effect on the

recording. Once the device is activated, it cannot be stopped. Adjustments can only be made for time setting and for changing the temperature measurement unit.

**Violations**

The Fridge-tag® has two temperature/ time limits to indicate a high and a low alarm. When a temperature / time violation occurs, the “OK” sign on the screen will be replaced by the “ALARM” sign.

As an example, the high alarm shall be set at >8 °C for more than 10 hours. The high alarm will then appear if the device is exposed to temperatures above 8 °C for more than 10 **consecutive** hours. The low alarm will appear if the device is exposed to temperatures below -0.5 °C for 60 **consecutive** minutes. If the continuous exposure is less than the time limit, an alarm will NOT be triggered. For example, if the device is exposed to temperature >8 °C for 9 hours, then the temperature returns to an acceptable range for 2 hours and then the temperature returns to >8 °C for another 9 hours, this will NOT trigger an alarm since the time required for a high alarm has not been reached in one go. However the cumulative exposure can always be seen in the history made even if there has not been an alarm (see below).

**How to Read the History**

The Fridge-tag continuously records the temperatures and indicates with the “ALARM” sign on the screen if any violation of the temperature / time limits has occurred. This information can always be viewed for the past 30 days.

When there was no alarm (no violation of set temperature / time limits), the “OK” sign on the screen continues to be seen. Even when the “OK” sign is on, the highest and lowest temperatures reached during the last 30 days can be seen. The time duration of the temperature exposures can also be seen.

Pressing **READ** once display the highest temperature reached and the cumulative time duration (hrs: min) that the temperature was above the given upper limit for the current day (“today”). During this operation a high or low flash indicates the high and low temperature setting and the day it corresponds to.

>8°C< (10hr) 0.5°C (60 min)	-29	-28	-27	-26	-25	-24	-23	-22	-21	-20	-19	--18	-17	-16	-15	-14	-13	-12	-11	-10	-9	-8	-7	-6	-5	-4	-3	-2	yesterd	today
	<b>OK</b>																		<b>12.1°C</b>	↑										
																	<b>00:34</b>													

Pressing **READ** a second time displays the lowest temperature reached and the cumulative time duration that the temperature was below the given lower limit for the current day. (“today”)

>8°C< (10hr) 0.5°C (60 min)	-29	-28	-27	-26	-25	-24	-23	-22	-21	-20	-19	--18	-17	-16	-15	-14	-13	-12	-11	-10	-9	-8	-7	-6	-5	-4	-3	-2	yesterd	today
	<b>OK</b>																		<b>2.9°C</b>	↓										
																	<b>00:00</b>													

If you continue pressing **READ** the details of older days such as “yesterd” ,”- “2 days”, “-3d” and so on for the previous 30 days can be viewed.

If the temperature/time limits are violated the **OK** sign disappears and **ALARM** sign appears. Without using the history mode, the day the alarm occurred and type of alarm can also be screen. The below example indicates three alarms on the days “yesterd”. (high alarm) and “-2 days” (high alarm and “-5d” (low alarm).

>8°C< (10hr) 0.5°C (60 min)	-29	-28	-27	-26	-25	-24	-23	-22	-21	-20	-19	-18	-17	-16	-15	-14	-13	-12	-11	-10	-9	-8	-7	-6	-5	-4	-3	-2	yesterd	today
	<b>ALARM</b> <span style="float: right;"><b>17:52</b>      ↓      <b>05.3°C</b>      ↑      ↑</span>																													

As previously explained you have to press **READ** button to have access to the information of highest and lowest temperature recorded and the period of the exposure above and /or below the set temperature limits. The example below shows **12 hours and 15 minutes** exposure to temperatures above the upper limit on the day “-2days”, and 25.0 °C as the highest temperature recorded.

>8°C< (10hr) 0.5°C (60 min)	-29	-28	-27	-26	-25	-24	-23	-22	-21	-20	-19	-18	-17	-16	-15	-14	-13	-12	-11	-10	-9	-8	-7	-6	-5	-4	-3	-2	yesterd	today
	<b>ALARM</b> <span style="float: right;"><b>12:15</b>      ↑      <b>25.0°C</b></span>																													

The example below shows 2 hours and 45 minutes exposure to temperatures below the lower limit on the day”-5d”, and “-5d”, and -5.7 °C as the lowest temperature recorded.

>8°C< (10hr) 0.5°C (60 min)	-29	-28	-27	-26	-25	-24	-23	-22	-21	-20	-19	-18	-17	-16	-15	-14	-13	-12	-11	-10	-9	-8	-7	-6	-5	-4	-3	-2	yesterd	today
	<b>ALARM</b> <span style="float: right;"><b>02:45</b>      ↓      <b>- 05.7°C</b></span>																													

## **IMPORTANT NOTES:**

### **Read out mode**

In order to avoid incorrect data, the Fridge-tag® does not collect any readings while in the Read out mode. Fridge-tag will fall back into normal operation after 30 seconds without pressing any buttons.

### **Time adjustment**

The number of possible time adjustments during a day is unlimited. But after any adjustment and the next midnight date shift adjustment mode is locked for 24hrs. This is for security reasons. Thus, a new setting is possible only after the 2nd date shift again.

### **Loc Display**

The Fridge-tag® prevents recordings of false data which could be caused by heat while holding the device in the hand. As soon as one of the buttons is pressed, the Fridge-tag® interrupts its measurement. After completing the handling of the device the word "Loc" appears on the display. For a period of 10 minutes, the Fridge-tag does not measure the temperature to avoid false readings until the environment temperature has been reached.

### **Liability**

The manufactures shall not be held liable:

- a) If the device was used beyond the manufacturer's given limitations.
- b) For any claims due to the improper storage and use of the device.
- c) For any problems with the cooling unit.
- d) For the bad quality of the monitored goods, if any.
- e) For incorrect readings if the device was used with activated low battery sign.

### **Battery**

The Fridge-tag® does not contain a CR Lithium battery, therefore please:

- a) Dispose or recycle in accordance to your local regulations.
- b) Do not expose the device to extreme temperature as it may lead to the destruction of the battery and may cause injuries.
- c) Keep out of reach of children
- d) The end of the battery life is indicated by low battery sign.  
Make sure to replace the device within 30 days when the low battery sign appears.

### **Useful life**

The operational life time of the unit is approx. 2 years after activation on the condition that:

- a. The device was not stored for over 1 year prior to activation.
- b. The read out mode is not excessively used e.g. several times a day.
- c. Storing & operating of the device remains inside the recommendations of the manufacturer, especially very low temperatures shall be avoided.

**Attention:** The Fridge-tag® monitors temperature exposure and not the product quality. Its purpose is to signal if product quality evaluation/testing is required.

## Appendix 7: Case Definitions - Surveillance of EPI Conditions

DISEASE	STANDARD CASE DEFINITION	DEFINITIONS for COMMUNITY PARTICIPATION
<b>Measles (Suspected Measles cases)</b>	History of a generalised blotchy rash (not blistering) AND •a history of fever AND •a history of at least ONE of the following: *cough *runny nose *red eyes	history of fever and rash
<b>Acute Flaccid Paralysis (AFP)</b>	Any case of sudden onset of floppy paralysis including Guillain- Barré Syndrome in a child less than 15 (fifteen) years of age for which no other cause is apparent, OR a patient of any age diagnosed as polio by a medical officer	<b>Sudden weakness or paralysis in the leg(s) AND/OR arm(s) not caused by injury in children under 15 (fifteen) years of age</b>
<b>Neonatal Tetanus</b>	History of normal suck and cry for the first two days of life AND •history of onset of illness between 3 and 28 days of age AND •history of inability to suck followed by stiffness AND/OR •convulsions AND •often death	<b>Any neonatal death OR a child born normal who stopped sucking and developed stiffness AND/OR jerking muscles AND/OR who died during the first month of life</b>
<b>Diphtheria</b>	•History of acute pharyngitis, acute nasopharyngitis, OR •acute laryngitis, with throat pseudomembrane	<b>Sore throat, with grey patch/patches in the throat</b>
<b>Pertussis/ Whooping cough</b>	•history of severe cough AND •a history of any one of the following: persistent cough for 2 or more weeks, fits of coughing, cough followed by vomiting AND/OR •typical "whoop" (in older infants and children)	<b>Severe cough persisting for 2 weeks or more</b>
<b>Adverse Events Following Immunisation (AEFI)</b>	Any medical incident that takes place after immunisation causing concern and it believe to have been caused by immunisation	<b>Any cause of concern with child after immunisation</b>

## Appendix 8: Case Investigation Form (AEFI)

Page 1 of 2		<b>Case Investigation Form: ADVERSE EVENTS FOLLOWING IMMUNISATION (AEFI)</b>				
<b>INSTRUCTIONS: This form should be completed in full for each AEFI case.</b>						
Official use only: <b>EPIDNUMBER:</b> _____ Received on ____/____/20____						
<b>IDENTIFICATION OF PATIENT</b>						
Surname of patient: _____						
First names of patient: _____						
Names of father/mother: _____						
Sex: Male Fem.						
Date of birth ____/____/____ Age ____ months ____ yrs						
Res. address / Contact information:						
Clinic/Hospital name: _____ Town: _____						
District: _____ Province: _____						
<b>REPORT / INVESTIGATION</b>						
Reported by: _____ Tel no: _____						
Date district notified: ____/____/20____ Date case investigation ____/____/20____						
<b>HISTORY OF IMMUNISATION</b>						
Date of immunisation: //20 Date of onset of event: //20						
Place of immunisation: Name of vaccinator:						
<b>VACCINES GIVEN TO PATIENT</b>				Manufacturer	BATCH No./ LOT No.	DOSE No.
BCG	Yes	No	Unk			
OPV	Yes	No	Unk			
RV	Yes	No	Unk			
DTaP-IPV/HIB	Yes	No	Unk			
Hep. B	Yes	No	Unk			
PCV	Yes	No	Unk			
Measles	Yes	No	Unk			
Td	Yes	No	Unk			
TT	Yes	No	Unk			
Other	Yes	No	Unk			
Specify vaccine:						
<b>TRIGGER EVENT Mark the trigger event with an X in the column provided</b>						
<b>Local reactions</b>				<b>Systemic reactions</b>		
	Severe local reaction (swelling extended more than 5cm from the injection site or redness and swelling for more than 3 days)				All cases of hospitalisation (thought to be related to immunisation)	
	Lymphadenitis				Encephalopathy within 7 days	
	Injection site abscess				Collapse / shock-like state within 48 hours	
					Seizures within 3 days	
					All deaths (thought to be related to immunisations)	
<b>DETAILS OF EVENT (Symptoms at time of onset)</b>						

**Case Investigation Form:****ADVERSE EVENTS FOLLOWING IMMUNISATION (AEFI)**

Official use only: <b>EPIDNUMBER:</b> _____				
<b>RESPONSE TO THIS EVENT</b>				
Treated at OPD	Yes	No	Unk	Admission Date: //20
Admitted to hospital for treatment	Yes	No	Unk	Hosp. No. _____
Name of hospital: _____				
Event explained to parent/guardian?	Yes	No	Unk	Interview Date: //20
Vaccinator guidance / retraining given	Yes	No	Unk	InterviewDate: //20
<b>HISTORY OF PREVIOUS REACTIONS TO IMMUNISATION AND/OR TREATMENT</b>				
Has this child had any previous reaction after immunisation?	Yes	No	Unk	
Was a history of any allergies in this child obtained?	Yes	No	Unk	
Was any information given prior to immunisation?	Yes	No	Unk	
Was the health status of the child assessed before immunisation?	Yes	No	Unk	
Were any other AEFIs reported from this clinic in the last 30 days?	Yes	No	Unk	
<b>FINAL CLASSIFICATION</b> (By provincial EPI coordinator in cooperation with national office)				
Programme Error	<input type="checkbox"/>			Coincidental <input type="checkbox"/>
Faulty vaccine	<input type="checkbox"/>			Unknown <input type="checkbox"/>
Give a brief reason for the classification:				
Date of final classification: //20				
<b>INVESTIGATOR:</b> Name		Tel:		
Position and facility/district		Fax:		



# Appendix 9: Immunisation Monitoring Chart

## IMMUNISATION MONITORING CHART: NUMBER OF CHILDREN IMMUNISED

HEALTH FACILITY NAME: \_\_\_\_\_ YEAR: \_\_\_\_\_  
 Facility Annual Target Population Under 1 yr(AT)<sup>1</sup>: \_\_\_\_\_ Facility Monthly Target Population (MT)<sup>2</sup>: \_\_\_\_\_

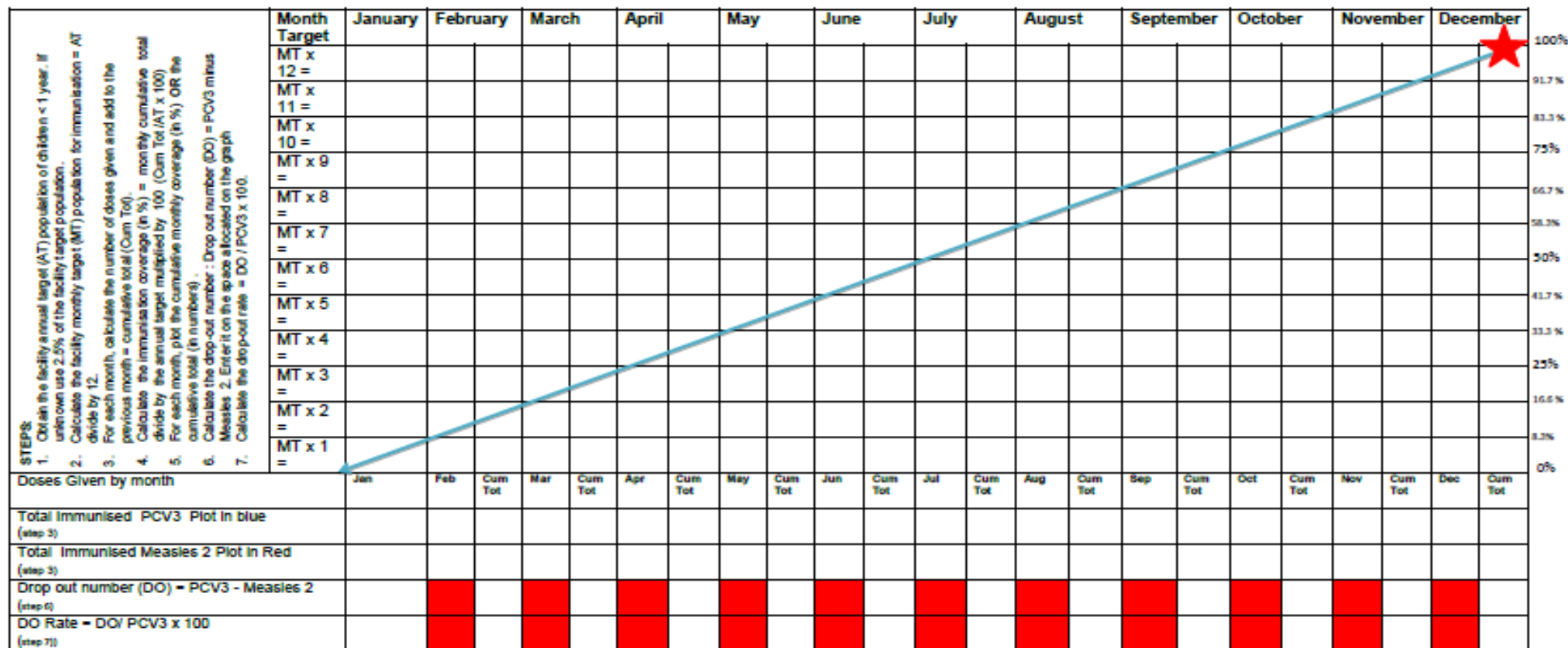

# IMMUNISATION MONITORING CHART: NUMBER OF CHILDREN IMMUNISED

HEALTH FACILITY NAME: \_\_\_\_\_ YEAR: \_\_\_\_\_

Facility Annual Target Population Under 1 yr(AT): \_\_\_\_\_ Facility Monthly Target Population (MT): \_\_\_\_\_

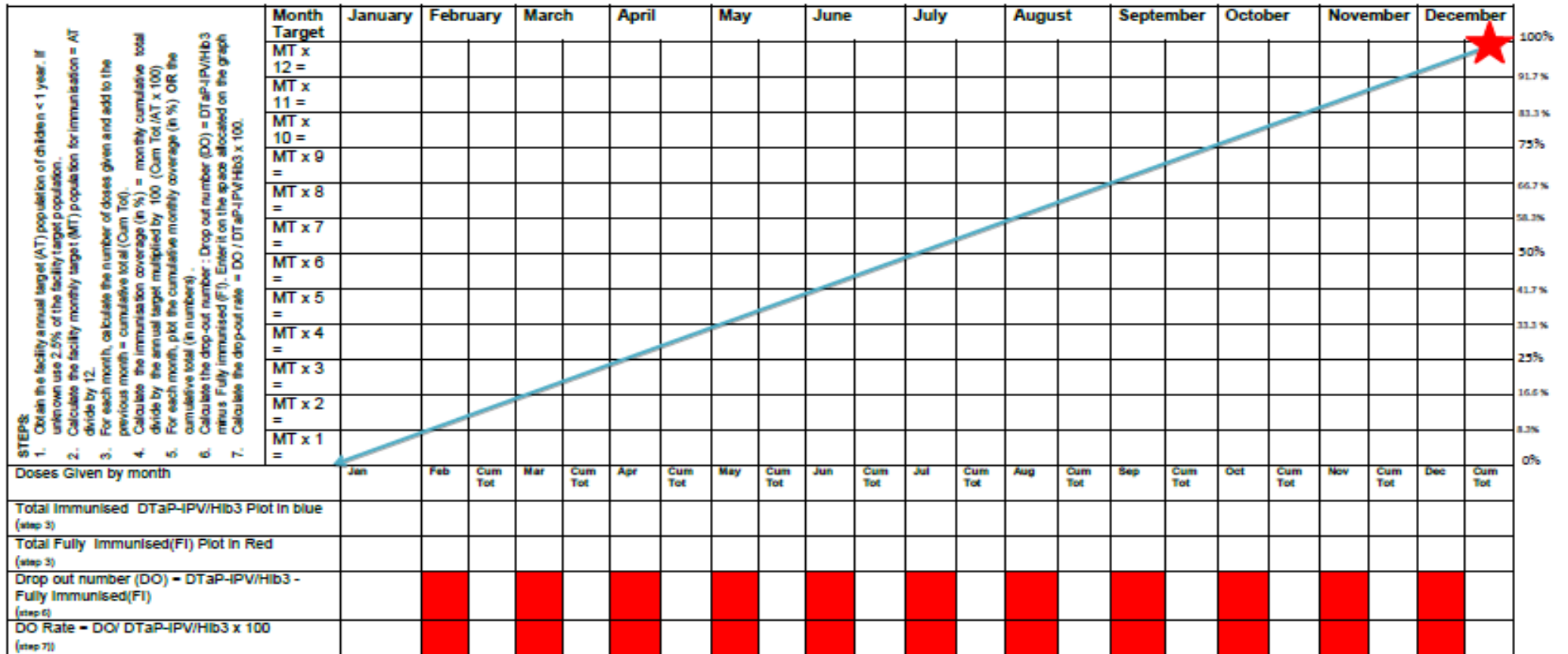

**Appendix 10: EPI-SA Integrated Communication Strategy Plan**

<b>Target Audience</b>	<b>Objectives</b>	<b>Activities</b>	<b>Communication channels</b>	<b>Output/outcome Indicators</b>	<b>Budget</b>

### Appendix 11: Health Facility Vaccination and Defaulter Tracing Register

HEALTH FACILITY VACCINATION AND DEFAULTER TRACING REGISTER																						
Use separate page(s) for each month using the date of birth to identify the children to be recorded in that particular month																						
Write the date of vaccination under the column for each dose given. Fill the date only when the child gets the dose. If for any reason the dose is not given, leave it blank.																						
Do not record date of vaccination under the second dose if the child was not given first dose; record it under the first dose. Do the same for all subsequent doses																						
Unique No.	Name & Surname Home Address Cell No.	Date of birth/ ID No.	Birth		6 Weeks					10 Weeks		14 Weeks			9 Months		18 Months		6 yrs	12 yrs		
			BCG	OPV 0	OPV 1	Hep B1	DTaP-IPV//Hib 1	RV 1	PCV 1	DTaP-IPV//Hib 2	Hep B2	DTaP-IPV//Hib 3	Hep B3	RV 2	PCV 2	Measles 1	PCV 3	Measles 2	DTaP-IPV//Hib 4	Td	Td	